

DOCUMENT RESUME

ED 113 676

CG 010 217

AUTHOR Wescourt, Keith T.; Atkinson, Richard C.
 TITLE Fact Retrieval Processes in Human Memory. Psychology and Education Series Technical Report No. 252.
 INSTITUTION Stanford Univ., Calif. Inst. for Mathematical Studies in Social Science.
 SPONS AGENCY National Science Foundation, Washington, D.C.
 PUB DATE 11 Apr 75
 NOTE 92p.; Not available in hard copy at author's request

EDRS PRICE MF-\$0.76 Plus Postage. HC Not Available from EDRS.
 DESCRIPTORS Cognitive Processes; Concept Formation; *Conceptual Schemes; Information Retrieval; *Memory; Models; *Reaction Time; *Recall (Psychological); Theories; *Thought Processes

IDENTIFIERS *Reaction Time Recognition Memory Paradigm

ABSTRACT

A major contribution of information-processing theory to the psychology of remembering is the concept of memory or information retrieval. Several theories of the fact retrieval processes of the human memory, which constitute a substrate for any cognitive ability requiring stored information, have drawn heavily on certain data processing constructs. This document is organized into three sections: (1) a definition of human fact retrieval and its implications for experimental investigations of memory, (2) theoretical constructs that have been used to formulate models of fact retrieval, and (3) the possible roles of temporal information and cues in experimental procedures for investigating human fact retrieval. The document considers the strengths and weaknesses of the current theoretical approach to memory that emphasizes the micro-processes and micro-structures. This approach is somewhat unique in its use of quantitative differences, as opposed to qualitative orderings, to resolve theoretical issues. The authors stress the influence of contextual cues on the fact retrieval process as well as problems related to complexity of research design, and conclude that it is not yet possible to design a single successful model of human fact retrieval. (Author/MF)

 * Documents acquired by ERIC include many informal unpublished *
 * materials not available from other sources. ERIC makes every effort *
 * to obtain the best copy available. Nevertheless, items of marginal *
 * reproducibility are often encountered and this affects the quality *
 * of the microfiche and hardcopy reproductions ERIC makes available *
 * via the ERIC Document Reproduction Service (EDRS). EDRS is not *
 * responsible for the quality of the original document. Reproductions *
 * supplied by EDRS are the best that can be made from the original. *

FACT RETRIEVAL PROCESSES IN HUMAN MEMORY

BY

KEITH T. WESCOURT AND RICHARD C. ATKINSON

PERMISSION TO REPRODUCE THIS
WORK AND MATERIALS BY MICRO-
FILM ONLY HAS BEEN GRANTED BY

Keith Wescourt
EDUCATIONAL INSTITUTIONS OPERAT-
ING UNDER AGREEMENTS WITH THE NA-
TIONAL INSTITUTE OF EDUCATION
FOR THE REPRODUCTION OUTSIDE
THE EDUCATIONAL SYSTEM REQUIRE PERMIS-
SION FROM THE ORIGINAL OWNER

TECHNICAL REPORT NO. 252

APRIL 11, 1975

U.S. DEPARTMENT OF HEALTH,
EDUCATION & WELFARE
NATIONAL INSTITUTE OF
EDUCATION

THIS DOCUMENT HAS BEEN REPRO-
DUCED EXACTLY AS RECEIVED FROM
THE PERSON OR ORGANIZATION ORIGIN-
ATING IT. POINTS OF VIEW OR OPINIONS
STATED DO NOT NECESSARILY REPRESENT
OFFICIAL NATIONAL INSTITUTE OF
EDUCATION POSITION OR POLICY

PSYCHOLOGY AND EDUCATION SERIES

INSTITUTE FOR MATHEMATICAL STUDIES IN THE SOCIAL SCIENCES

STANFORD UNIVERSITY
STANFORD, CALIFORNIA



ED 13676

CS 010 217



TECHNICAL REPORTS

PSYCHOLOGY SERIES

INSTITUTE FOR MATHEMATICAL STUDIES IN THE SOCIAL SCIENCES

Place of publication shown in parentheses, if published title is different from title of Technical Report, this is also shown in parentheses.

- 165 L. J. Hubert, A. G. J. Veltman, and J. G. W. van der Schoot. The effect of the processing of geometric configurations. February 1, 1971. (A statistical method for the study of the perceptual distance in a geometric configuration. *Journal of Mathematical Psychology*, 1972, 9, 389-403.)
- 166 J. F. Juola, E. C. F. H. J. G. J. W. van der Schoot, R. C. Atkinson. Recognition time for information stored in long-term memory. (*Perception and Psychophysics*, 1971, 10, 8-14.)
- 167 R. L. Klatzky and R. C. Atkinson. Specialization of the cerebral hemispheres in scanning for information in short-term memory. (*Perception and Psychophysics*, 1971, 10, 332-338.)
- 168 J. D. Fletcher and R. C. Atkinson. An evaluation of the Stanford CAI program in initial reading (grades K through 3). March 12, 1971. (Evaluation of the Stanford CAI program in initial reading. *Journal of Educational Psychology*, 1972, 63, 597-602.)
- 169 J. F. Juola and R. C. Atkinson. Memory demands for words versus categories. (*Journal of Verbal Learning and Verbal Behavior*, 1971, 10, 522-527.)
- 170 E. S. Fuchs and J. F. Juola. Effect of repeated tests on recognition time for information in long-term memory. *Journal of Experimental Psychology*, 1971, 91, 54-58.
- 171 P. Suppes. Semantics of context-free fragments of natural languages. March 30, 1971. (In K. J. J. Hintikka, J. M. E. Moravcsik, and P. Suppes, *Essays, Approaches to natural language*. Dordrecht: Reidel, 1973. Pp. 221-242.)
- 172 J. Friend. INSTRUCT coders' manual. May 1, 1971.
- 173 R. C. Atkinson and K. M. Shiffrin. The control processes of short-term memory. April 19, 1971. (The control of short-term memory. *Scientific American*, 1971, 224, 82-90.)
- 174 P. Suppes. Computer-assisted instruction at Stanford. May 19, 1971. (In *Man and computer*. Proceedings of international conference, Bordeaux, 1970. Basel: Karger, 1972. Pp. 298-330.)
- 175 D. Jamison, J. D. Fletcher, P. Suppes, and R. C. Atkinson. Cost and performance of computer-assisted instruction for education of disadvantaged children. July, 1971.
- 176 J. Offer. Some mathematical models of individual differences in learning and performance. June 28, 1971. (Stochastic learning models with distribution of parameters. *Journal of Mathematical Psychology*, 1972, 9(4), 311-321.)
- 177 R. C. Atkinson and J. F. Juola. Factors influencing speed and accuracy of word recognition. August 12, 1971. (In S. Kornblum (Ed.), *Attention and performance IV*. New York: Academic Press, 1973.)
- 178 P. Suppes, A. Goldberg, G. Kanz, B. Searle, and C. Stauffer. Teacher's handbook for CAI courses. September 1, 1971.
- 179 A. Goldberg. A generalized instructional system for elementary mathematical logic. October 11, 1971.
- 180 M. Jerman. Instruction in problem solving and an analysis of structural variables that contribute to problem-solving difficulty. November 12, 1971. (Individualized instruction in problem solving in elementary mathematics. *Journal for Research in Mathematics Education*, 1973, 4, 6-19.)
- 181 P. Suppes. On the grammar and model-theoretic semantics of children's noun phrases. November 29, 1971.
- 182 G. Kreisel. Expository notes on the application of proof theory to computer science. December 10, 1971.
- 183 J. M. Moloney. An investigation of college student performance on a logic curriculum in a computer-assisted instruction setting. January 28, 1972.
- 184 J. E. Friend, J. D. Fletcher, and R. C. Atkinson. Student performance in computer-assisted instruction in programming. May 10, 1972.
- 185 R. L. Smith, Jr. The syntax and semantics of ERICA. June 14, 1972.
- 186 A. Goldberg and P. Suppes. A computer-assisted instruction program for exercises on finding axioms. June 23, 1972. (*Educational Studies in Mathematics*, 1972, 4, 429-449.)
- 187 R. C. Atkinson. Ingredients for a theory of instruction. June 26, 1972. (*American Psychologist*, 1972, 27, 921-931.)
- 188 J. D. Bonvillian and V. R. Chirrow. Psycholinguistic implications of deafness. A review. July 14, 1972.
- 189 P. Arabie and S. A. Boorman. Multidimensional scaling of measures of distance between categories. July 26, 1972. (*Journal of Mathematical Psychology*, 1973, 10, 311-321.)
- 190 J. Ball and D. Jamison. Computer-assisted instruction for dispersed populations. System 10 (1971), September 15, 1972. (*Instructional Science*, 1973, 1, 469-501.)
- 191 W. R. Sanders and J. R. Ball. Logic presentation system for the Institute for Mathematical Studies in the Social Sciences. October 4, 1972.
- 192 M. T. Kline. Variability in the proof behavior of college students in a CAI course in logic as a function of problem characteristics. October 11, 1972.
- 193 P. Suppes. Facts and fiction of education. October 18, 1972. (In M. G. Wittrock (Ed.), *Changing education: Alternatives from theoretical research*. Englewood Cliffs, N. J.: Prentice-Hall, 1973. Pp. 6-35.)
- 194 R. C. Atkinson and J. F. Juola. Search and decision processes in free information memory. October 27, 1972.
- 195 P. Suppes, R. Smith, and M. Leavelle. The French syntax and semantics of PHILIPPE, part 1. November 1, 1972. (November 3, 1972.)
- 196 D. Jamison, P. Suppes, and S. Wolf. The effectiveness of alternative instructional methods. A review. November, 1972.
- 197 P. Suppes. A survey of cognition in human-computer interaction. December 29, 1972.
- 198 B. Searle, P. Linton, Jr., A. Goldberg, P. Suppes, N. Leifer, and C. Jones. Computer-assisted instruction in geometry. Technical State University. February 14, 1973.
- 199 D. R. Levine. Computer-based analytic training for German grammar instruction. March 16, 1973.
- 200 P. Suppes, J. D. Fletcher, M. Zanotto, P. V. Lorton, Jr., and B. W. Searle. Evaluation of computer-assisted instruction in elementary mathematics for hearing-impaired students. March 17, 1973.
- 201 G. A. Huff. Geometry and formal linguistics. April 27, 1973.
- 202 C. Jenkinson. Useful techniques for applying latent trait mental-test theory. May 9, 1973.
- 203 A. Goldberg. Computer-assisted instruction: The application of the theory of probability to instruction. June 11, 1973.
- 204 R. C. Atkinson, D. J. Hermann, and K. T. Westcott. Search processes in recognition memory. June 8, 1973.
- 205 J. Van Campen. A computer-based introduction to the morphology of Old Church Slavonic. June 18, 1973.
- 206 R. B. Kimball. Self-optimizing computer-assisted tutoring: Theory and practice. June 25, 1973.
- 207 R. C. Atkinson, J. D. Fletcher, E. J. Lindzey, J. O. Campbell, and A. Barr. Computer-assisted instruction in initial reading. July 9, 1973.
- 208 V. R. Chirrow and J. D. Fletcher. English as the second language of deaf students. July 20, 1973.
- 209 J. A. Paulson. An evaluation of instruction in logic for a sample learning population. July 30, 1973.
- 210 N. Martin. Conference proceedings of a workshop probably to adapt to the needs of the equal opportunity act. July 31, 1973.

FACT RETRIEVAL PROCESSES IN HUMAN MEMORY

Keith T. Wescourt and Richard C. Atkinson

Stanford University

Stanford, California 94305

Perhaps the most ubiquitous contribution of information-processing theory to the psychology of remembering is the notion of memory retrieval. In its broadest sense, retrieval refers to the utilization of information previously stored in memory. However, a distinction can be drawn between cases where the information required from memory for a particular application is stored "directly" and where it must be generated indirectly by "problem solving" or inference from other stored information (Feigenbaum, 1970). The two types of retrieval correspond to a distinction between computer fact retrieval systems and question answering systems (Anderson and Bower, 1973). This chapter is concerned with the fact retrieval processes of human memory.

During the past decade, cognitive psychologists have expended considerable energy attempting to specify precisely the nature of the human fact retrieval system. In part, this effort reflects a meta-assumption stating that higher-order cognitive processes (e.g., reasoning, problem solving, language comprehension) may be understood in

The preparation of this chapter was supported by a grant from the National Science Foundation (NSF-EC 43997). We wish to thank Richard Mohs, Lee Rothstein, Edward Smith, and Robert Solso for their comments on an earlier draft of this chapter.

terms of elemental micro-processes and micro-structures: that is, that cognitive abilities may be regarded as arbitrarily complex sequences composed from a single set of simpler cognitive operations. Attention has been focused, therefore, on human fact retrieval since logically it constitutes a substrate for any cognitive ability requiring stored information.

The contents of this chapter are organized into three sections. First, we consider a definition of human fact retrieval and its implications for experimental investigations of memory. Then, we describe theoretical constructs that have been used to formulate models of fact retrieval. Finally, we examine the possible roles of temporal information in experimental procedures employed to investigate human fact retrieval. The term temporal information is used here to refer to: 1) temporal variables in effect during the acquisition of information that determine its organization in memory (e.g., the grouping of to-be-remembered items in memory as a function of their interpresentation intervals) and 2) non-contextual familiarity differences between queries to the memory system that influence how they will be processed (e.g., the interval between two presentations of the same question as it influences the response to the second presentation). We are concerned with temporal information in memory because several theoretical issues hinge on questions about the locus and degree of its influence in tasks employed to study fact retrieval.

One of our goals in this chapter is to consider the strengths and weaknesses of the current theoretical approach to memory that emphasizes the micro-processes and micro-structures. This approach is

perhaps unique in its use of quantitative differences, as opposed to qualitative orderings, to resolve theoretical issues. As a result, our discussion in some places is more complex than in other chapters in this volume. To offset this complexity, we will emphasize connections between issues and will examine representative theories and data, instead of trying to catalogue the vast number of investigations that have been reported within the past decade.

Human Memory as a Fact Retrieval System

As a preliminary, we will introduce some terminology to help clarify when we are talking about physical objects and events and when we are talking about hypothetical memory structures and processes. Objects, their states, and the actions involving them that are to be remembered are encoded as (mapped into) concepts and relations and stored as memory structures.¹ A set of associated memory structures constitutes a data base. Questions are probes of memory and are encoded into probe structures consisting of the same concepts and relations that comprise memory structures. The terms concept, relation, memory structure, data base, and probe structure refer to hypothetical entities and are to be distinguished from terms referring to observable experimental objects and events.

Remembering: fact retrieval vs. inference

While fact retrieval is involved in performing tasks that also require reasoning and problem solving, there seem to be tasks for which "pure" fact retrieval is an adequate characterization of behavior. Such tasks involve the search of a data base for a match to a probe structure, where the ability (or inability) to locate a match is

¹The question of how to represent information in memory is an important concern not only in psychology, but also in philosophy, linguistics, and artificial intelligence (see, e.g., Bobrow & Collins, 1975). Rather than endorse a particular notation, we will employ the neutral term structure except when a specific type of representation seems convenient for heuristic purposes. As will become clear, however, statements about processing often depend on assumptions about representation.

sufficient to determine an appropriate response to the question at hand (see Figure 1).² Consider the distinction between memory for personal events versus general knowledge (see Tulving's, 1972, discussion of episodic vs. semantic memory): for instance, an individual's memory that he was bitten by a dog while walking home yesterday versus his knowledge that dogs can bite. For the former, there is a strong intuition that the event is represented in a specific memory structure and that the ability to answer the question "Did a dog bite you while walking home yesterday?" hinges on locating that structure in memory. If this intuition is correct, then the process of answering the question would be an instance of fact retrieval. On the other hand, the facts of general knowledge seem to be available by other means, specifically by inference from several stored memory structures that are related but may have been acquired in different contexts. For example, while most individuals probably do not have a separate memory structure representing "Macaws lay eggs", they are able to determine the veracity of this proposition by applying rules of inference to several facts (e.g., "Macaws are like parrots", "Parrots are birds", and "Birds lay eggs") that are stored as separate memory structures.³ This is not to say that pure fact retrieval is never sufficient to answer questions

²This definition of fact retrieval has been elaborated by Anderson and Bower (1973).

³Many theories about how people verify facts of general knowledge include some type of inference as a process of primary importance (e.g., Collins & Quillian, 1972; Smith, Shoben, & Rips, 1974).

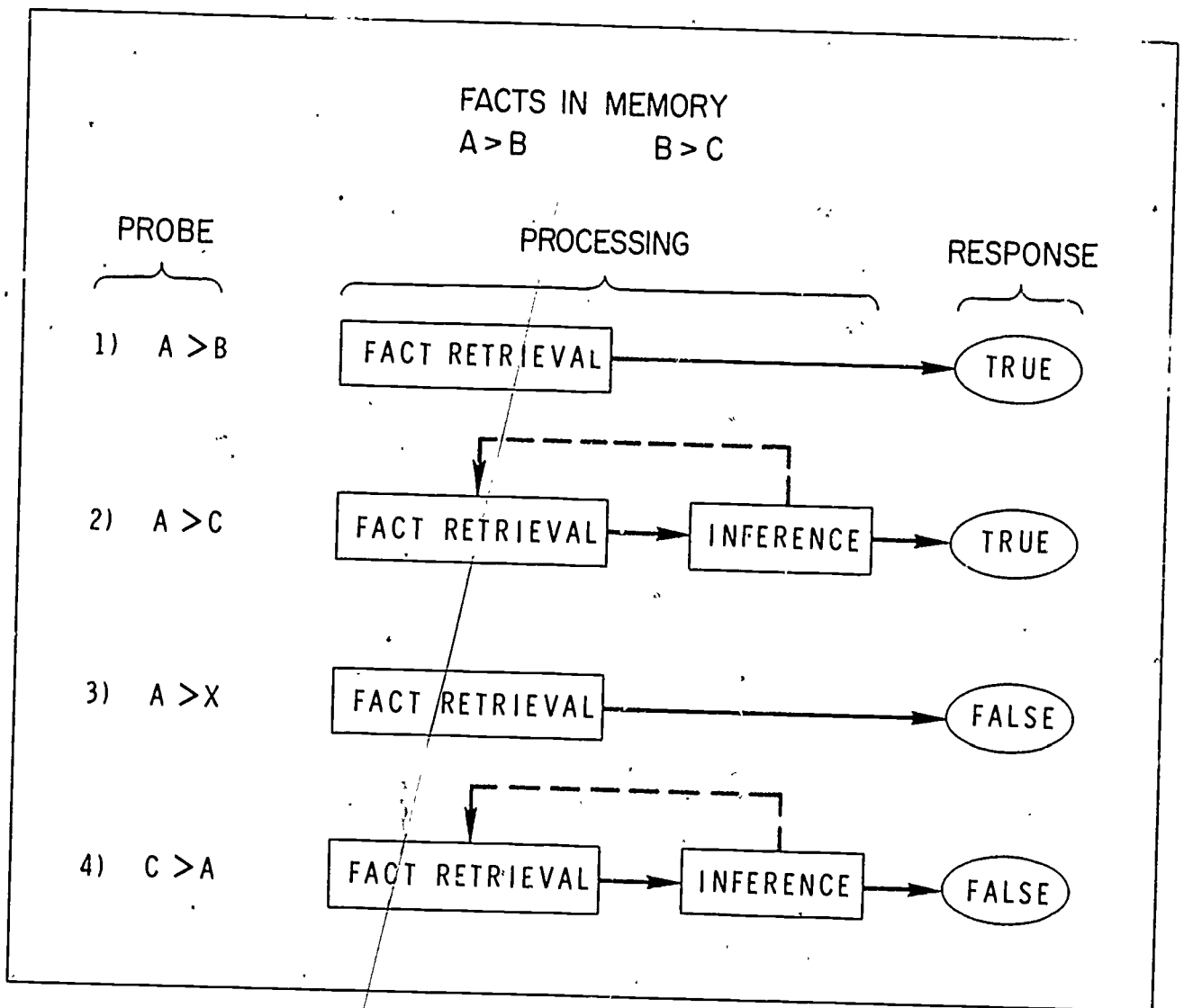

Figure 1. Schematic representation of situations where fact retrieval processes are and are not sufficient for responding to a probe. The data base consists of two algebraic inequalities. In row 1 the probe matches one of the items in the data base and fact retrieval is sufficient to determine a positive response; likewise, in row 3 fact retrieval can determine a negative response. In rows 2 and 4 fact retrieval of the inequalities in the data base is involved, but the response depends on additional processing (inference based on previously stored knowledge about algebraic rules). The dashed lines indicate that fact retrieval and inference processes may reiterate, rather than occur in a fixed sequence.

about general knowledge. It is certainly possible that some individuals have a structure "Macaws lay eggs" stored directly in memory as a result of seeing a macaw lay an egg or simply having been told that they do. However, a good deal of such knowledge probably involves synthesizing information from several separate memory structures, rather than fact retrieval alone.

On the other hand, while probes about personal events often elicit responses based on pure fact retrieval, this need not always be so. Consider, for example, a question about what you ate for dinner last Monday. Even if you cannot retrieve from memory the fact "I had a hamburger for dinner on Monday", you still might be able to answer by inference from other retrievable facts: for example, "I watch football on TV every Monday at the Oasis Beer Garden", "Monday football is on at dinner time", "The only thing at the Oasis that doesn't give me heartburn is their hamburgers". Thus, to isolate the fact retrieval component of human memory, it is not sufficient to limit the investigation to memory for personal events. It is necessary, in addition, to eliminate or at least minimize the possible role of inference and to explicitly characterize that role where it exists.

Considerations for studying fact retrieval

These observations about the role of inference in responding to questions suggest some requirements for tasks designed to investigate fact retrieval processes. It seems that such tasks should conform to three criteria:

- 1) The facts to-be-remembered are defined and acquired in the

experimental situation so that responses to subsequent test probes cannot be made on the basis of any extra-experimental knowledge.

- 2) The test questions are in some sense isomorphic to the to-be-remembered facts, thereby increasing the likelihood that the probe structures are encoded in the same format as the stored memory structures, so that a process involving the comparison of probe and memory structures is a sufficient basis for responding.
- 3) The probable mappings between the to-be-remembered events and their corresponding memory structures can be specified, thereby constraining the range of different data bases that might be stored by subjects.

These three criteria are met to varying degrees by many of the tasks used by experimental psychologists to investigate memory. Such tasks most often involve presenting experimental subjects with novel lists of items (words, pictures, letters, etc.) and subsequently testing their retention of these items. This procedure satisfies the first criterion to the extent that subjects' prior knowledge cannot aid them in answering the question, "Was item 'x' part of the list you were shown?". With respect to the second criterion, test questions vary widely in their correspondence to the original to-be-remembered events. On the one hand, a simple recognition probe, "x" (implicit question "Was 'x' part of the list"), may be physically identical to the display in which "x" was originally presented. On the other hand, the test probes of free recall ("What items were part of the list?") or context recall

("What item followed item 'x' on the list') bear a decreasing resemblance to the physical events that occurred when the list was presented. The ability of tasks to satisfy the third criterion is most difficult to evaluate. Simply presenting a list of items to be remembered does not insure that facts of the form "item x is part of LIST A" are represented in memory: consequently, responses to a test probe "x" ("Was item 'x' part of LIST A") may involve more than simple fact retrieval. Instead, responses could be based on inference from other stored facts: for example, "Item y is part of LIST A", "Item x followed item y", and thus, by inference, item x was probably also part of LIST A. Further, rather than infer the response to a question, the question could conceivably be transformed and answered by fact retrieval involving memory and probe structures different from those assumed by the investigator; for instance, in the previous example, the probe "x" could be translated by the subject to mean "Did item 'x' follow another item on LIST A", thereby allowing a response by matching the stored structure "Item x followed item y". In practice, it is difficult to appraise different laboratory procedures with respect to our three criteria. It seems clear, nonetheless, that tasks showing the most a priori promise for investigating fact retrieval are those that involve recognition memory for novel information.

Control processes of retrieval: intuitions and assumptions

An idea of central importance in this chapter is that the human fact retrieval system-- the processes that encode probe structures, search memory structures, and ascertain matches-- is organized such that

available information can be used to control its operations. Thus, fact retrieval is a context-sensitive group of processes that may function with measurable differences in efficiency from one moment to the next or from one situation to the next. Later we will describe some examples of control processes in retrieval; at this point, we want to consider some intuitions about control processes.

It seems almost trivial to observe that memory search (initiated in response to a question) must be organized or directed in some way.⁴ When we consider search in its commonsense meaning, we usually think of a sequential examination of locations; for example, rummaging through drawers one at a time. The tractability of such a search depends on the number of locations. Given the innumerable facts known by the average person, sequential examination of the entire contents of memory seems to be an unlikely mechanism, especially when one considers the rapidity with which people can respond to most questions. Such a search is particularly difficult to reconcile with the fact that we often know immediately that we cannot answer a question. If sequential search occurs in human memory, then the set of memory structures examined must be constrained in some manner so as to limit the search. There is a temptation to cite introspective evidence with regard to this hypothesis. It is true that deliberate attempts to remember are sometimes accompanied by the conscious impression of sequential search; the facts examined seem not to be random, but related instead to one another and to the question at hand. For example, in trying to recall a

⁴See Landauer (1975), for a critique of this intuition.

phone number, we may retrieve and reject several numbers as well as information about people and places associated with them. We are less likely to think about the previous day's football scores or about the fact that "a canary is a bird". Thus it appears that the probe initiates a search through a set of stored structures that are related in some way to the probe or to each other. This set might be either preselected before memory search or determined during the search with some aspect of each retrieved memory structure affecting the search processes involved in locating the next structure. The problem with this type of introspective data is that it may reflect processes subsequent to fact retrieval. Conscious awareness of memory search generally occurs when we have difficulty in answering a question, indicating perhaps that the search for a directly stored answer has failed. Subsequent introspections might then be viewed as an aspect of higher-order inference processes attempting to derive an answer. At present, there are only a few investigations (e.g., Anders, 1971) of the relationship between subjects' introspections and hypothesized memory search processes; consequently it is difficult to evaluate the usefulness of introspections as an independent source of evidence.

Assumptions about the control of retrieval processes are implicit in most experimental investigations of memory. The experimenter believes that the variables he manipulates are the primary determiners of performance and that idiosyncratic differences in the subjects' prior experience can be ignored. When a subject learns a list of words and is later tested for retention, performance depends primarily on the acquisition and retrieval contexts-- not on events of

the previous day, week, or year. Thus theoretical explanations of performance begin by assuming that the subject has the ability to focus his memory system on the structures stored during the experiment, and that retrieval operations involve only these structures.⁵

While experimenters often have been willing to ignore idiosyncratic differences among their subjects, much consideration has been given to differences in normative variables that characterize the to-be-remembered materials. The effects of word frequency, concreteness, and imagery value on memory are well documented in the literature (see, e.g., Hall, 1971, ch 3 & 4; Murdock, 1974, ch. 3 & 5). However, theoretical issues involving the effects of material variables are difficult to resolve, largely because these variables are established from group norms (i.e., their values are determined statistically for a population of subjects). For example, a high frequency associate of a word has that property for a proportion of a population, whereas a word repeated three times in a list has that property for everyone who learns the list. Furthermore, distinctions between groups of items based on differences in normative variables may be confounded with physical differences that exist between the groups (see Landauer & Streeter, 1973). Attempts to study fact retrieval processes by manipulating material variables thus may have limited value because these factors can introduce unpredictable differences in the data bases stored by different subjects. Such experiments can produce

⁵This is not to say that subjects don't think about other things during experimental sessions, but rather that such thoughts have no systematic effect on how they perform.

misleading results when the usual practice of averaging subjects' data is followed

The fact retrieval framework and the study of forgetting

Until recently, psychological research on memory focused on factors influencing relatively gross aspects of learning and forgetting lists of items; the central question was, what causes memory to fail? Unfortunately, this orientation and the related experimental methods do not address themselves to theoretical issues regarding the micro-properties of memory processing that are a focus of the fact retrieval approach. The study of interference phenomena exemplifies some of the difficulties involved in applying the earlier research on verbal learning to the task of fleshing out details of an information processing description of human memory (see Murdock, 1974, Ch. 4). Interference research has specified circumstances under which the processing of certain facts can result in the forgetting of other facts. However, the information processing mechanisms underlying performance are not readily discerned in the relationships between independent variables and the number of forgotten items; this measure of retention does not characterize memory processes per se, but rather, the processes' end result. Therefore, the answers provided by such data are not at the same level of analysis as the questions posed within the information processing framework. By analogy, studying patterns of the changing values of stocks (while perhaps enabling one to make a profit in securities) does not provide a sufficient basis for understanding how the economy operates.

There is a further problem in applying certain types of forgetting data to the study of fact retrieval processes. It may be possible to infer in an instance of forgetting that a particular memory process failed, without being clear about which other processes were executed successfully. In situations where people are motivated to remember but cannot always do so (e.g., in a laboratory memory task), it is almost certain that they attempt to apply constructive inferential processes in addition to fact retrieval, and that these processes vary from effort to effort. Thus performance reflects an unknown mixture of processes, making it difficult to specify the precise nature of the individual processes involved.

Reaction-time measures of memory performance

Since data from contexts where memory fails has limited value for specifying fact retrieval processes, investigation has come to rely primarily on techniques for studying contexts where memory succeeds. The data are most often reaction times (RT) of responses to test probes of some highly available data base.⁶ An implicit assumption is that under circumstances that insure successful retrieval and encourage a speeded response, RT is a measure of the duration of the minimal processing required to respond correctly.⁷ This approach, which has been

⁶Highly available in the sense that either error-free retention or the learned information can be demonstrated when there is no time constraint or that very few errors occur when there is an emphasis on fast responding.

⁷To the extent that some errors occur in almost any task, the analysis of RT data is subject to considerations about speed-accuracy trade-offs (Pachella, 1974).

carefully articulated by Sternberg (1966, 1969a, 1969b, 1974), often assumes that RT reflects a sum of component times associated with underlying processing stages. By applying the additive factors method to the design and analysis of such tasks, stages can be statistically isolated and subsequently identified (within the information processing framework) with hypothesized operations like encoding, decision making, and memory search. In brief, this technique involves examining the pattern of interactions of several factors on RT. Factors that do not interact (i.e., whose effects on RT are additive) are assumed to selectively influence different processing stages. The effects of these factors on RT permits one to estimate the duration of the different stages and thus the hypothesized operations:

In Sternberg's original studies, one task required the subject to decide as quickly as possible whether or not a test probe (a single digit) was a member of a previously presented set of digits. This task and variants of it will be referred to as the RT recognition memory paradigm. Features of this task and hypothesized retrieval processes are illustrated in Figure 2. The subject is presented with a set containing some number of items (usually called the memory set). Presumably, the subject stores a data base associating a LIST node, a HAS-AS-PARTS (H-A-P) relation node, and nodes representing each memory set item; the labels on the associations (links between nodes) indicate which nodes are subjects and objects of the relation. This representation is adapted from network theories of memory (e.g., Anderson & Bower, 1973; Rumelhart, Lindsay, & Norman, 1972) and is intended only to be sufficient for our examples. Relations such as

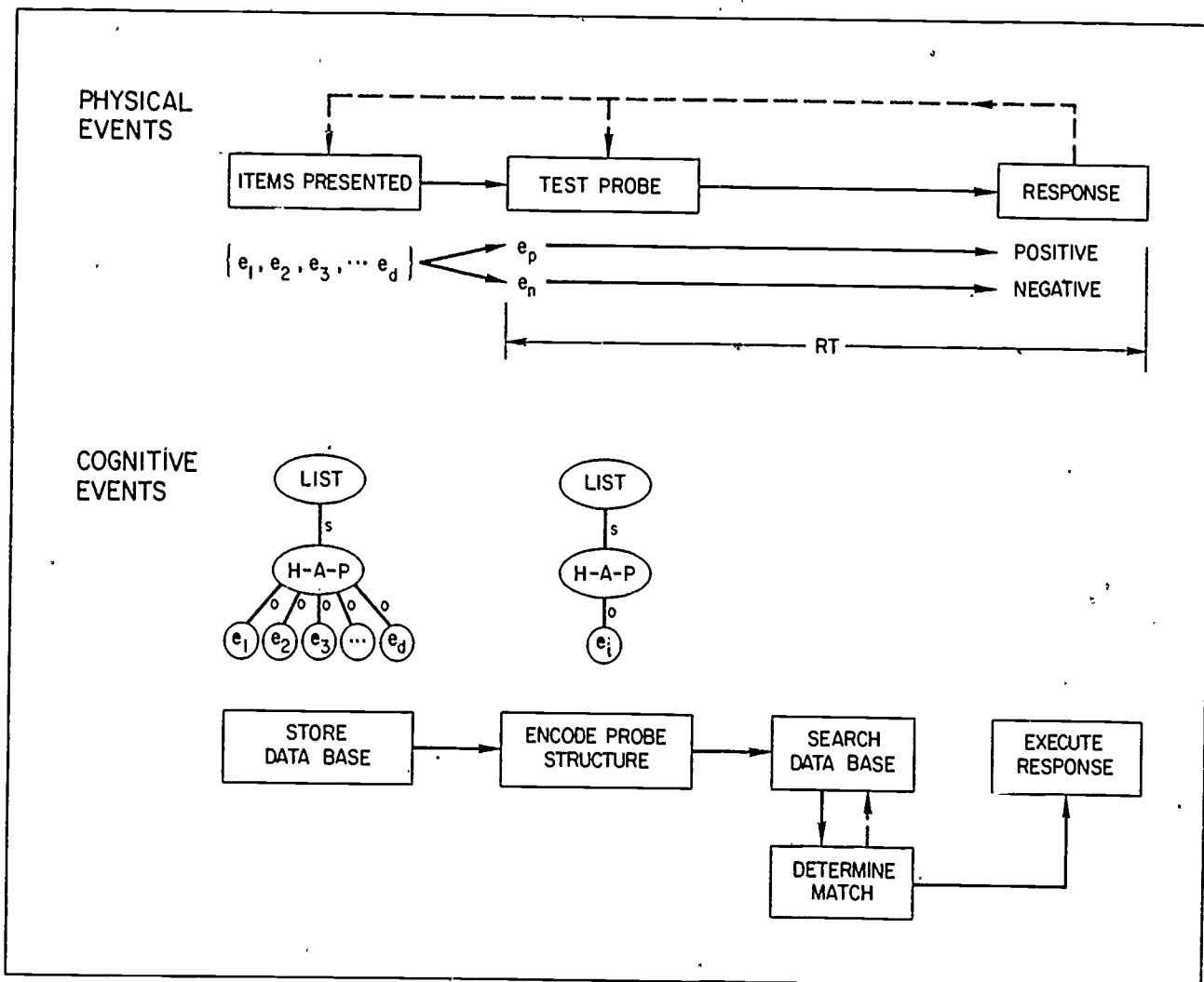

Figure 2. Physical events and their corresponding hypothetical cognitive events in a RT item-recognition memory task (see text for explanation). The stages of searching the data base and determining the outcome of that search are separated because these operations are distinguishable in some models and may occur in varying sequences.

HAS-AS-PARTS are assumed to be primitives in these theories. Other representations (e.g., predicate calculus, feature or property lists) could also encode the same information, but a network representation is easily diagrammed.

After studying the memory set, the subject is presented with a test probe, which requires a positive response if it is identical to one of the memory set items and a negative response otherwise; RT is measured from the onset of the test probe. In Figure 2, the test item is encoded as a probe structure to be compared with the data base. This comparison involves searching the data base and determining if there is a match. For example, given the memory set "8 2 5 7", the subject makes a positive response to the probe digit "5" or a negative response to "6" by pressing an appropriate switch that stops a timer started at the probe's onset. The important results of Sternberg's experiments are that 1) RT increases linearly with memory set size and 2) the slope of the function is independent of the effects of several experimental manipulations that are assumed to influence only encoding and decision stages. Sternberg interpreted the effects of memory set size in terms of its influence on a stage involving sequential memory search (see Figure 3) The slope of the RT vs. set size function is the duration of a comparison between the probe and an item in the memory set and the intercept is the duration of all processes other than memory search.

Extensions of Sternberg's paradigm for studying fact retrieval

Many investigators have adopted Sternberg's (1969a, 1969b) assumption that factors affecting the slope of the RT vs. set size

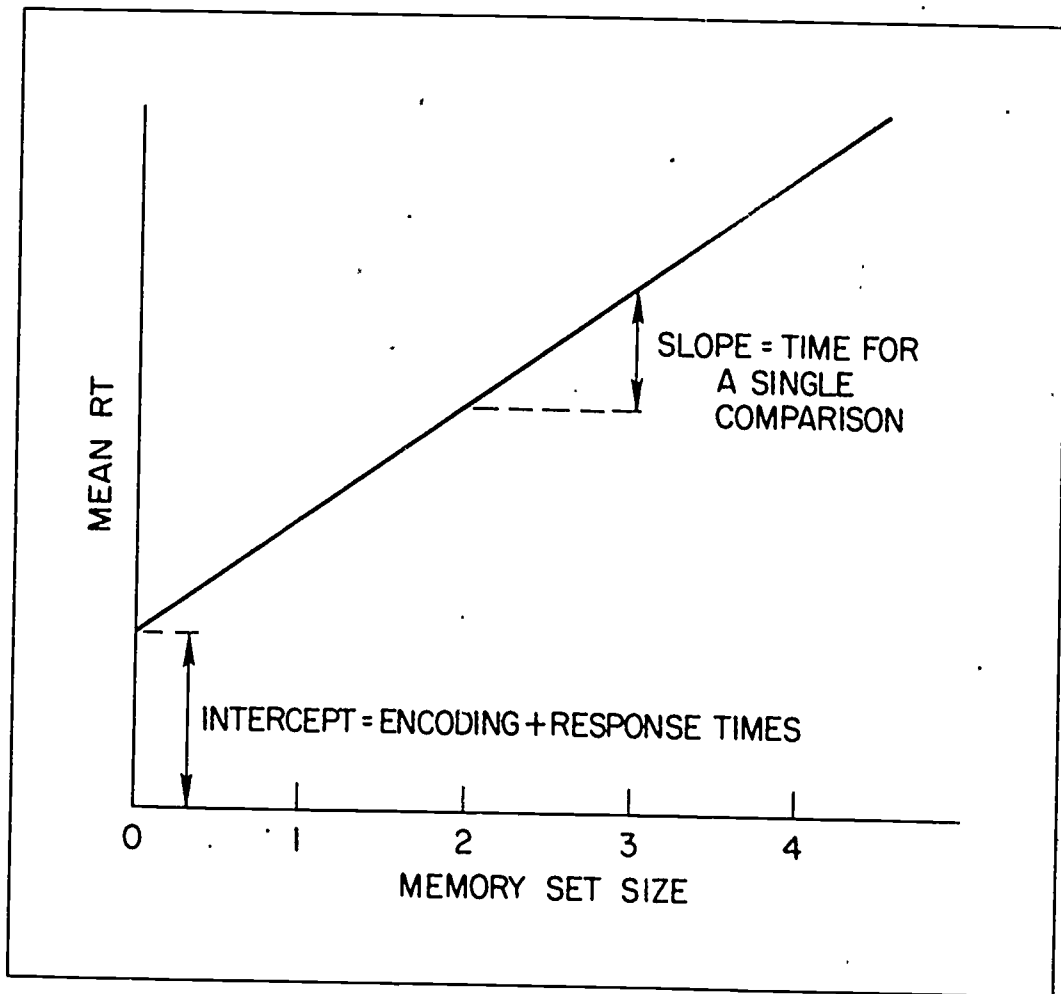

Figure 3. Relationship between RT and memory set size in a RT item-recognition memory task.

function (i.e., factors that interact with the set-size factor) influence only memory search.⁸ Two extensions of the RT recognition memory paradigm seem to provide useful data for considering more detailed hypotheses about retrieval processes. The first involves imposing an organizational scheme on the items in the memory set. An example is presenting a set of digits divided into two subsets, one containing only odd digits and the other only even digits; the test probe is then a single digit, the decision being whether or not the probe was in either subset. We refer to the subset having the same category value as the test probe as the relevant subset and the other subsets as irrelevant. If the test probe were the odd digit "5", then the subset of odd digits would be the relevant subset and the subset of even digits would be the irrelevant subset. Using organized memory sets, hypotheses about search processes can be evaluated by examining the functions relating RT to the size of the total memory set and to the sizes of the relevant and irrelevant subsets. In particular, this procedure provides a basis for determining what information can be used by the subject to preselect a set of memory structures for comparison with a probe structure.

A second extension of the RT recognition memory paradigm involves defining some translation function and instructing the subject that his response is to be based on whether or not a test probe can be mapped into the memory set (or vice-versa) by the function. For

⁸ Almost all this research suffers the criticism that it assumes the independence of encoding, search, and decision stages rather than ascertaining it experimentally for each modification of the task.

instance, if memory set consists of several digits, then a test probe might be the display "2+?=5", meaning "Is the sum of 2 and any digit in the memory set equal to 5?". There are two obvious ways in which this question could be answered: 1) by solving the equation and forming a probe structure "LIST H-A-P 3" that is then compared against the structures in the data base, or 2) by forming a probe structure "LIST H-A-P 5" and then translating each memory set item by adding 2 before comparing it with the probe structure. These alternative processes predict RT vs set-size functions that differ from those obtained in tasks where no translation is required. In the first case, there is additional processing to solve the equation before forming the probe structure. Since this process precedes memory search, the intercept of the RT vs. set-size function should increase, but the slope should be not be affected. In the second case, additional processing occurs for each memory structure that is compared to the probe structure; thus the slope should be greater than in tasks where no translation is necessary. Different translations, requiring different types of additional processing, provide an opportunity to study the efficient control of fact retrieval processes (efficient in terms of minimizing response time for a test probe).

The next section describes hypothesized fact retrieval processes and their relationship to data from various types of RT recognition memory tasks.

Mechanisms of Fact Retrieval

Non-directed and directed search processes

The memory search stage in fact retrieval models generally involves two classes of processes: non-directed and directed search (Oldfield, 1966; Shiffrin & Atkinson, 1969). Non-directed search refers to the comparison of a probe structure with each memory structure in a predefined set of memory structures; the a priori probability of a match is assumed to be the same for each of the memory structures. Directed search locates a set of memory structures using information that is available before and during the search stage; the structures in the set are equally likely candidates as a match to the probe structure, all other structures having been eliminated as possible matches. (Obviously, the notion of a directed search process does not correspond to commonsense meanings of "search".)

In tasks where minimal time constraints are placed on responding (like free recall), retrieval may involve irregular reiteration between directed and non-directed search processes (Shiffrin, 1970); consequently, the extent of processing is not easy to specify, making it difficult in turn to use these data to make inferences about the precise nature of the search processes. On the other hand, in RT recognition memory tasks, time constraints and a highly available data base make multiple retrieval attempts unlikely; thus, RT data can be used to specify a minimal sequence of non-directed and directed search processes.

In a non-directed search process a negative outcome involves determining a mismatch between the probe structure and each member of a set of memory structures. Two classes of non-directed search, self-terminating and exhaustive, are defined according to whether comparisons between the probe structure and memory structures stop or continue when a match with the probe occurs. Under the assumption that the expected duration of each comparison is the same, self-terminating and exhaustive searches are distinguished by differing relationships between the RT vs. set-size functions for positive and negative probes. In a self-terminating search, the slope of the RT vs. set-size function for positive responses is less than that for negatives, since on the average fewer comparisons are required to determine a match than a mismatch. On the other hand, these slopes are expected to be equal when search is exhaustive, since the number of comparisons is the same as the memory set size for both positive and negative probes (see Figure 4).

Using the relation between positive and negative slopes to distinguish between self-terminating and exhaustive processes is appropriate only when the time to determine a match and a mismatch is the same; if processing times vary between matches and mismatches, then almost any relation between positive and negative slopes is possible. Processing times can vary when concepts and relations are represented componentially (e.g., as lists of features or attributes) rather than as elemental entities. A comparison process then might involve the evaluation of differing numbers of components in order to determine matches and mismatches (e.g., finding one incongruent component might be sufficient to mismatch two concepts, whereas all components might have

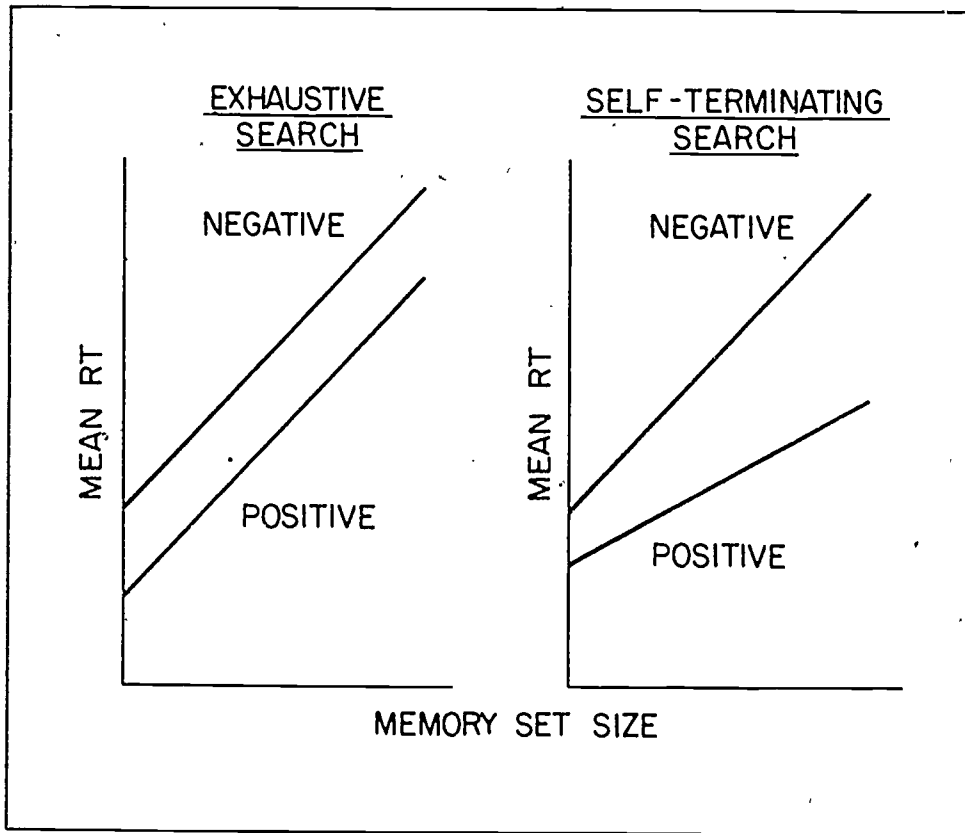

Figure 4. Expected relationships between positive and negative slopes given exhaustive and self-terminating search processes. The slopes are equal for exhaustive search; for self-terminating search, the slope of the function for negative test probes is twice that for positive probes.

to be congruent to determine a match). In certain types of visual matching tasks, subjects are required to respond 'same' or 'different' to two test patterns. When test patterns are manipulated with regard to component features, RT for mismatches varies directly with the similarity of the patterns (Nickerson, 1967). Comparable results have been found in RT recognition memory tasks that vary the similarity of negative test items to items in the memory set (Atkinson & Juola, 1973, Exp. 4; Chase & Calfee, 1969; Checkosky, 1971). Nevertheless, for reasons of simplicity and tractability, search models have generally assumed that comparison time is the same for matches and mismatches.

Another exception to the use of positive-negative slope differences to distinguish exhaustive and self-terminating processes is demonstrated in a model proposed by Theios (1973). In this model, the data base has special structural properties and contains the sets of both positive and possible negative probes. The appropriate response for each item is stored with it in the data base. These features, coupled with self-terminating processing, generate predictions for equal positive and negative slopes in Sternberg's (1966) RT item-recognition memory task.

The notion of an exhaustive comparison process seems counterintuitive when the test involves a positive probe. Why should the entire memory set be examined when it would appear that the most efficient strategy is to respond as soon as a match occurs? The answer is that under certain conditions an exhaustive search can take less time than a self-terminating search. Let us consider Sternberg's (1969b) analysis. He proposes that comparing a probe structure with a memory

structure and determining the outcome of that comparison are two distinct operations (see Figure 5). In this scheme, one could compare and immediately determine the outcome of the comparison operation before moving to the next memory structure; alternatively, one could first make all of the comparisons and only then determine whether one of them resulted in a match. To respond correctly in the RT item-recognition memory task, it is sufficient to determine that a match occurred somewhere during search without noting which particular memory structure matched the probe structure. When the determination process takes longer than the comparison process, it is more efficient to perform all the comparisons before determining whether a match occurred, rather than to switch back and forth between the two operations. This proposal implies that there is some control process over the sequencing of search operations that creates efficient strategies. In addition, it implies that self-termination represents a form of retrieval control rather than an elementary mechanism of memory search.

Serial vs. parallel processing

Our discussion thus far may seem to imply that non-directed search (whether self-terminating or exhaustive) involves sequential comparison operations, as proposed by Sternberg (1969b). However, models proposing that comparison operations occur in parallel over the set of memory structures also predict increasing (and under certain assumptions linear) RT vs. set-size functions, thereby entailing a distinction orthogonal to that of self-terminating vs. exhaustive comparisons. In a parallel search, matching operations between a probe

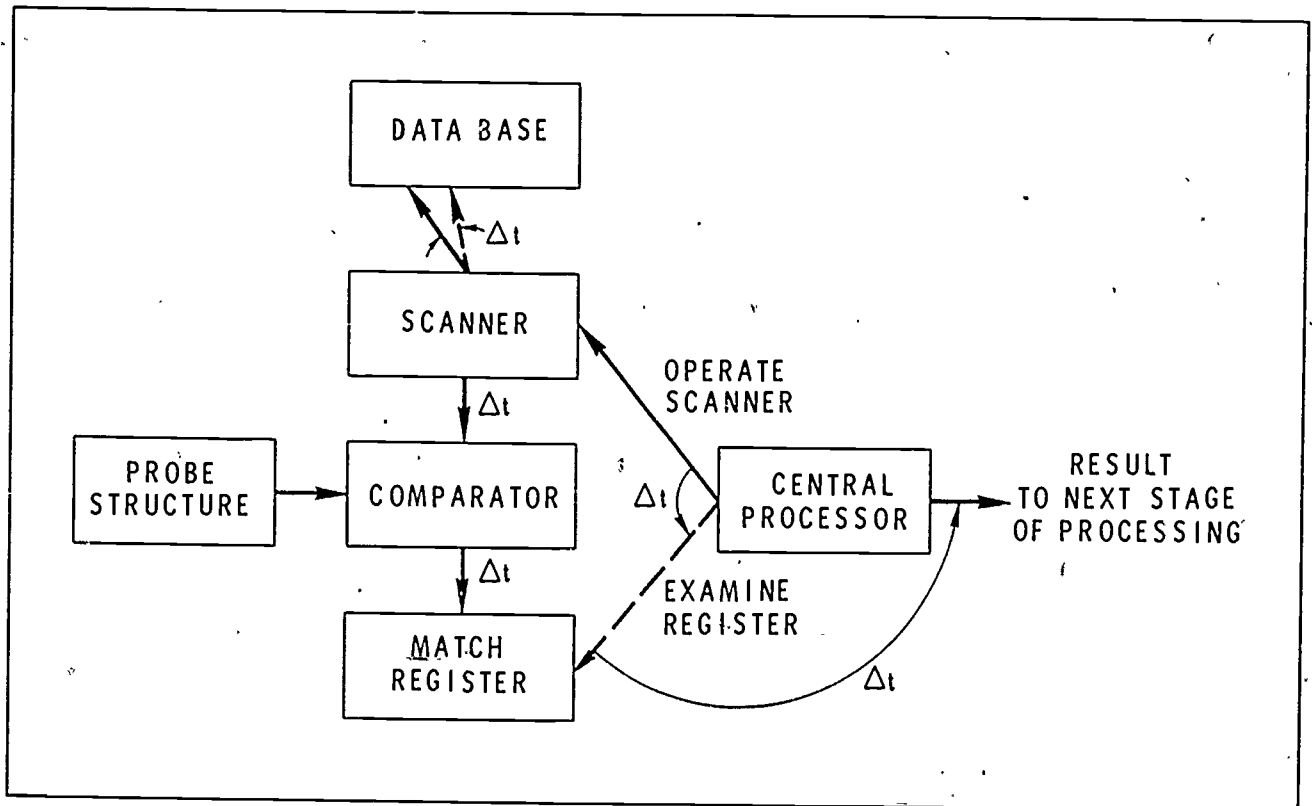

Figure 5. A system in which exhaustive search could be more efficient than self-terminating search. Some loci of possible time delays are represented by Δt . The central processor is limited at any moment to either operating the scanner or examining the match register to determine the outcome from the comparator. (The comparator matches the probe structure against memory structures found by the scanner.) Exhaustive search is more efficient when the time required to shift between the scanner and match register is large relative to the time required to scan memory structures in the data base. (Modified after Sternberg, 1969b.)

structure and several memory structures are simultaneous. Parallel processes are alien to the commonsense notion of search, but constitute alternative explanatory mechanisms for a range of data. There are physical analogies to a parallel search process; for example, a resonating tuning fork will cause a tuning fork of similar pitch to resonate, allowing a determination of whether or not a set of tuning forks contains one of that pitch.

Theoretical analyses have suggested that particular serial and parallel processes may not be formally distinguishable on the basis of RT data (Atkinson, Holmgren, & Juola, 1969; Shevell & Atkinson, 1974; Townsend, 1971, 1974). For example, while Sternberg (1966) demonstrated that unlimited capacity parallel-search models have properties inconsistent with his data (specifically, with properties of observed RT means and variances) there are limited capacity parallel processes formally equivalent to his proposed serial exhaustive search model (Murdoch, 1971; Shevell & Atkinson, 1974; Townsend, 1974).⁹ The problem of identifiability does not mean, however, that either a serial or parallel processing model might not be preferable to the other, based on other considerations such as parsimony or possibly physiological data. The real difficulty lies in gaining consensus about considerations that go beyond behavioral measures like RT. For instance, Sternberg (1974)

⁹A limited capacity parallel process postulates a finite amount of processing "energy" that is distributed among comparisons such that the greater their number, the less energy each one gets and thus the slower its rate. In an unlimited capacity parallel process, the rate of a comparison is independent of the number of other ongoing comparisons. For further details see Townsend (1974).

rejected alternative parallel search models for his results largely because he found the limited capacity processing assumption to be vague and arbitrary; yet, limited capacity processing is a construct that has been widely accepted in information processing analyses of other tasks (see Darley, 1974; Kahneman, 1973; Townsend, 1974).

Implications of serial position data for search processes

Additional evidence for distinguishing between self-terminating and exhaustive search processes are RT vs. serial position functions for positive test probes. Serial position refers to the ordinal position in a memory set of the item matching the probe item; for example if a memory set contains the digits "5 3 8 9" presented in that order and "3" appears as the probe digit, then its serial position is two. An exhaustive process implies that RT does not depend on the serial position of an item within a memory set. Self-terminating serial searches imply serial position effects if positions are examined in a fixed order; similarly, position effects are expected from a self-terminating parallel process when the distribution of processing capacity across positions is unequal, but fixed from test probe to test probe (Townsend, 1974). Sternberg (1969b) found no effects of serial position in his RT item-recognition memory experiments, further supporting the contention that the memory search was serial and exhaustive.

A serial, self-terminating search seems to be the most parsimonious model for a given set of data when the following conditions hold: 1) the RT vs set-size functions for both positive and negatives

responses are linear, with the positive function having half the slope of the negative function: 2) RT increases linearly over serial positions for a fixed set size, with a slope equal to the slope of the RT vs. set-size function for negatives responses; and 3) the same serial positions for different memory set sizes have identical mean RT. There are few, if any, experimental results consistent with all three conditions; the third condition is rarely observed, even when the first two are obtained. Sternberg (1969b) in evaluating the efficiency of exhaustive searches (see preceding discussion and Figure 5) presented data from a RT context-recall task and also from a RT context-recognition memory task. In the RT context-recall task, subjects were presented with a memory set consisting of digits and then with a single test digit to which they responded by calling the name of the digit that immediately followed it in the memory set. Subjects in the RT context-recognition task were presented with similar memory sets and were tested with a pair of digits; they were required to make a binary response regarding whether the test digits were in the same or reverse order with respect to their order in the memory set. In contrast to item-recognition tasks (where it is sufficient to determine that a match has occurred without knowing which item matched), responses in context-recall and context-recognition tasks require a determination of whether a match has occurred after the completion of each comparison. The results of both the context-recall and context-recognition tasks indicate that search processes in these situations differ from those in item recognition: The RT vs. set-size slopes are greater than in the item recognition task, and RT increases with serial position in both

tasks This led Sternberg to propose that the memory search was serial and self-terminating. However, in the context-recognition task, the RT data for the same serial positions in different size memory sets clearly did not coincide (e.g., less time was needed to respond "same order" for test digits in positions two and three in a four-digit memory set than for digits in the same positions in a six-digit memory set). Therefore, Sternberg's characterization of the search process in this task is not completely supported by the data.

Subsequent research has found serial position effects in RT item-recognition memory tasks that are difficult to reconcile with a serial search process (Burrows & Okada, 1971; Clifton and Birenbaum, 1970; Okada & Burrows, 1973; Raeburn, 1974). These serial position functions are non-linear and show a marked recency effect; that is, RT is more or less constant over serial positions except for the last few positions where it decreases. This result is most often obtained when the interval between the presentation of the last memory set item and the onset of the test probe is short (usually less than one second). It remains to be determined whether this critical duration reflects an actual difference in the processes used to respond to a probe, or a difference in the state of the memory structures due to uncontrolled rehearsals of the memory set at longer intervals. Rehearsal could lead to implicit, random re-ordering of the memory set before each test, eliminating any relation between RT and experimenter defined serial position.

Content-addressable storage

As was noted earlier, it is implicitly assumed, in most laboratory studies of memory that retrieval is restricted to appropriate information; that is, that search is directed to data bases relevant to the task. Ideas about this aspect of directed search tend to be fairly general and not compelled by particular empirical results. One conjecture is that memory is organized along temporal, perceptual, and/or semantic dimensions; a given data base is stored in memory at a location specified by the values on these dimensions of the information represented in the data base. At retrieval, the analysis of available information (from either the immediate context or a previous retrieval operation) suggests the intersection of dimensions at which to enter memory. (Atkinson, Herrmann, & Wescourt, 1974; Atkinson & Wescourt, 1975) This process constitutes a type of content-addressable memory-- a term borrowed from computer science-- reflecting that the storage and retrieval of information depends on the nature of that information. Most filing systems utilize content-addressable storage; files are coded according to dates, names, and topics and a query for filed information generally contains data that suggest the file or files where the information is located. While this analogy with a filing system is too simple to be applied to human memory, some type of content-addressability is either explicit or implicit in most theories of human memory.

A limiting case of content-addressable memory is direct-access

retrieval, where non-directed search is completely bypassed.¹⁰ Information provided by the test probe and/or the retrieval context is sufficient to locate an appropriate memory structure which (when compared to the probe structure) provides the basis for a response. By analogy, it is as if one had to determine whether a particular document existed in a file system and knew from the description of the document (the probe) and the organization of the file system that, if the document were present, it would have to be located in a particular folder and that no other documents would be in that folder. Direct-access retrieval in human memory has been inferred when responses to a test probe are unaffected by the nature or extent of information that the subject was asked to remember (McCormack, 1972). One would expect that the amount of information should influence non-directed search processes; thus, if the subject's responses are independent of the amount of information, we have evidence favoring a direct access process.¹¹ For instance, direct-access retrieval has been postulated in

¹⁰ However, direct access does not imply content addressability. Modern digital computers have direct-access core memories that are location-addressable.

¹¹ It must be stressed again that this type of theoretical inference is based on considerations of parsimony rather than logical necessity. If comparison times for memory structures varied with their extent and organization, as it might under the assumption that concepts and relations are stored componentially (Bower, 1967; Norman & Rumelhart, 1970), then almost any effects of amount and organization of to-be-remembered information could be consistent with either direct access or with non-directed search processes. For example, if the number of components per concept decreased with the number of structures stored, then comparison time per structure could decrease as number of structures increased; this trade-off might eliminate any effect of memory set size on RT.

models for accuracy recognition memory tasks where there are no effects of memory set size and organization on performance (Kintsch, 1970, McCormack, 1972; cf. Jacoby, 1972).¹²

Search within an organized data base

Hypothesized content-addressable retrieval processes depend on the enduring, and perhaps intrinsic, organization of memory stores. A second category of directed search processes are those that utilize the idiosyncratic organization of a data base to restrict the number of memory structures that need to be examined in response to a probe. Like content-addressable retrieval mechanisms, the operation of these processes depend on the availability of information about the internal organization of the data base and the relationship of a probe to this organization. Variants of the RT recognition memory paradigm provide a means for investigating directed search processes by considering the joint effects of organization and set size. Organizing a memory set might provide a basis for partitioning the data base stored by the subject; hypotheses that the search for a match to a probe structure is directed toward (or away from) some partition can be evaluated by analyzing the relations between number of partitions, partition sizes, and RT.

Figure 6 indicates how an organizational variable (a semantic

¹²Results from lexical decision tasks (which required a speeded decision about whether or not a letter string is a word) have been interpreted as evidence that information about individual words is stored in a semantically organized memory and can be retrieved by a direct-access process (Meyer, Schvaneveldt, & Ruddy, 1975).

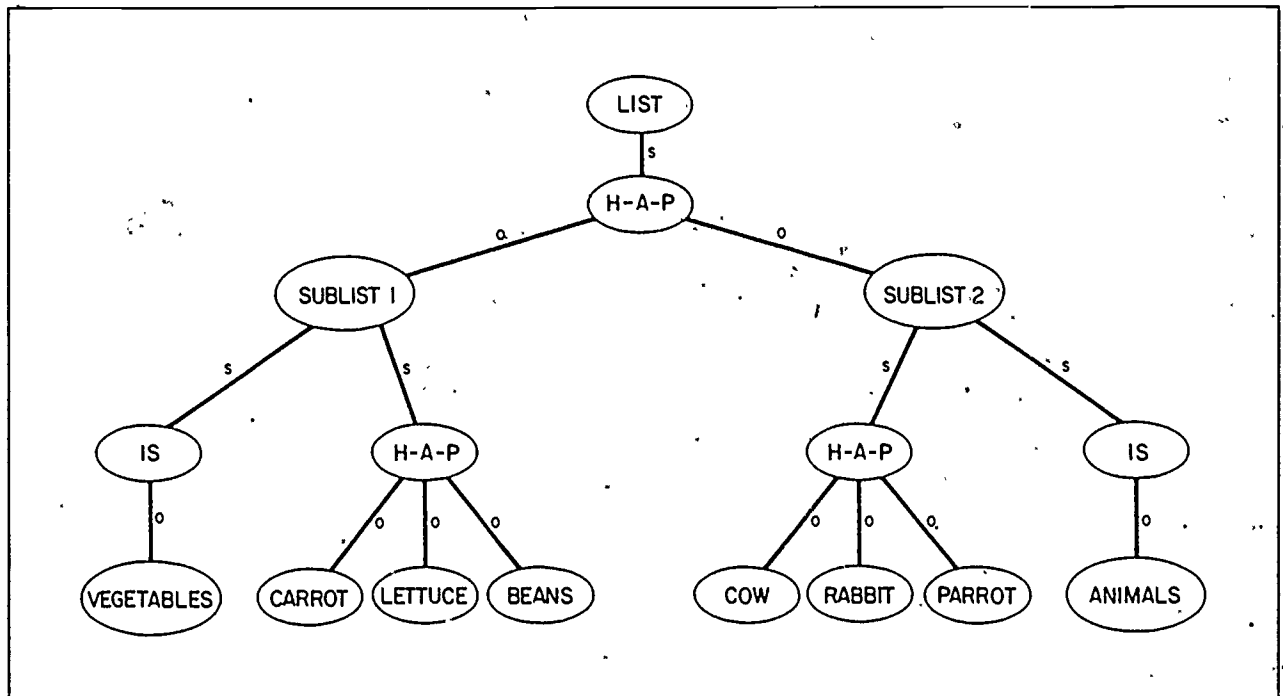

Figure 6. Schematic of a data base representing a word list organized on the basis of taxonomic category membership. The list is structured as two sublists. Associated with each sublist are the words that are part of it and also information about the category they belong to. The category information is generated by the subject if not supplied by the experimenter at the time the list is presented for study.

dichotomy) might structure the data base that is formed in memory when a small word list is presented. The list is structured as two subsets, based on the membership of the words in taxonomic categories. A directed search making use of this structure might go as follows (see Figure 7). When the probe "carrot" is presented, it is encoded as "LIST H-A-P VEGETABLE 'carrot'": note that in encoding the test word, information that "carrot" belongs to the category VEGETABLE is incorporated into the probe structure. The data base is entered at the LIST node (direct access assumed) and the associations from that node are checked so that a match to "LIST H-A-P" is first ascertained. At this point, there are two alternative paths and an initial non-directed search is attempted; that is, one of the alternatives is randomly chosen. If it leads to the ANIMAL partition, then the category information will fail to match the probe and the search will back up to the choice point without examining any of the animal-name words. The VEGETABLE partition will then be examined and a match will be found. If the initial choice is the VEGETABLE partition, then the ANIMAL partition of the data base will not be examined. Similarly, negative probe words should lead to an examination only of the relevant category partition; e.g., if the vegetable "asparagus" appears as a test item, it will be compared only against the concepts in the VEGETABLE partition of the data base. The duration of these operations should therefore reflect the number of categories and the size of the relevant category subset, but not the sizes of irrelevant category subsets. This type of processing

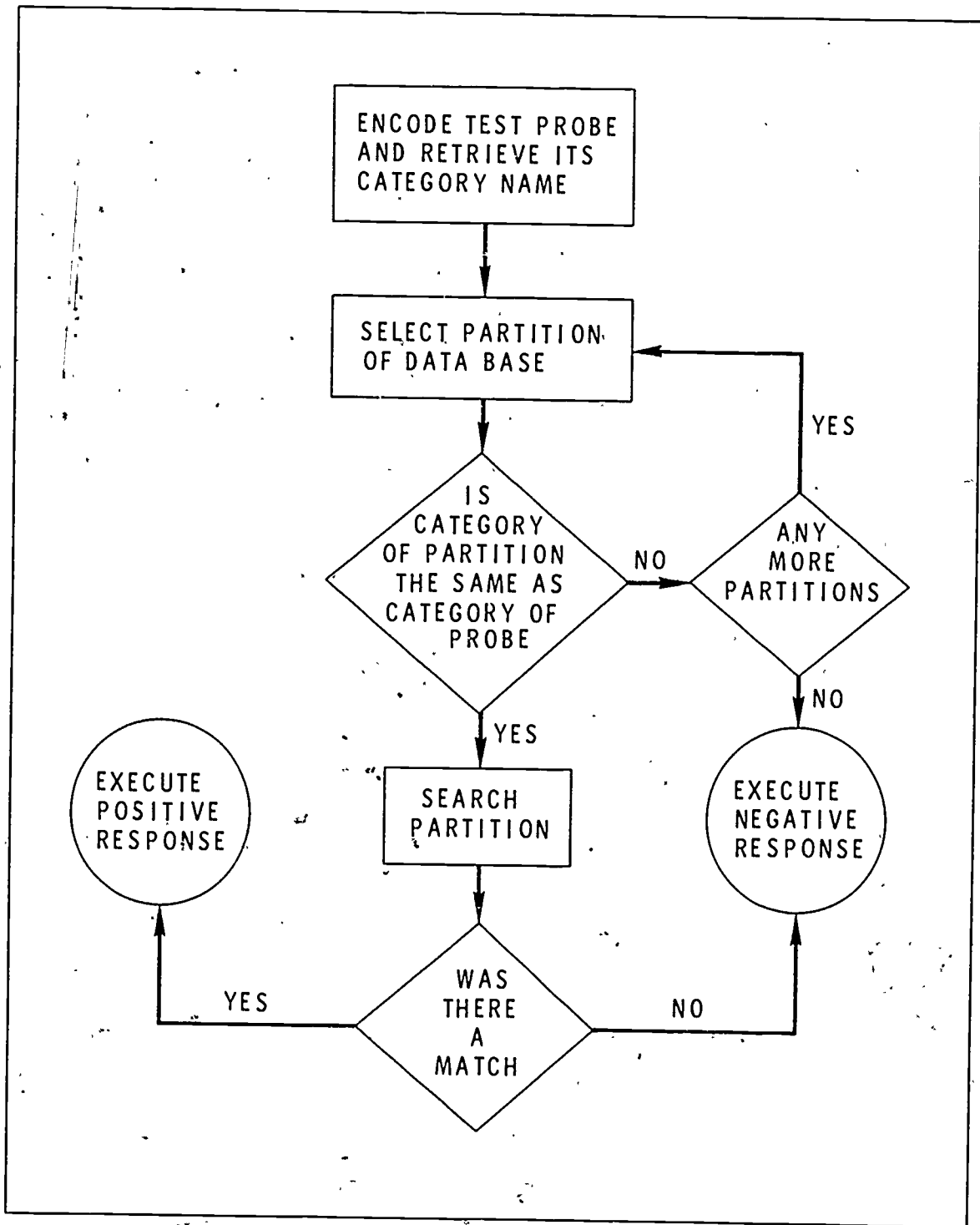

Figure 7. Flow chart of a directed-entry search process for an organized data base. The test item is compared only with memory set items that belong to the same category.

has been called a directed-entry search process (Naus, 1974).¹³

Several investigators have interpreted the results of experiments employing semantically or perceptually divided memory sets as evidence in favor of a directed-entry search model (Crain & DeRosa, 1974; Homa, 1973; Kaminsky & DeRosa, 1972; Seamon, 1973; Williams, 1971). They found that RT increased with size of the relevant subset, but not with total memory set size (i.e., RT did not depend on irrelevant subset sizes). When number of subsets was manipulated, RT also increased with increasing numbers of subsets, as expected in a directed-entry search model. Additional support for a directed search process involves a comparison of results for negative probes that are selected from categories not represented in the memory set (external negative probes) and those that are unrepresented exemplars of categories represented in the memory set (internal negative probes). RT for external negative probes is faster than for internal negative probes and varies much less, or not at all, with memory set size (Homa, 1973; Lively & Sanford, 1972; Okada & Burrows, 1973; Williams, 1971; cf. Landauer & Ainslie, 1973). Therefore, responses to external negative probes may be based on category membership information (processed during directed search) without a non-directed search of the memory set items.

¹³ Search could also be directed if category names were not explicitly present in the data base and probe, but were retrieved from pre-existing knowledge bases only after the first word in the first subset examined was compared to the probe word. Retrieving contradictory category information at this point could also allow the search to back up to the original choice point. These alternative representations of the data base might be differentiated by examining the effects of factors known to influence verification time for pre-existing semantic knowledge (see, Rips, Shoben, and Smith, 1973); in the case that this knowledge is retrieved and represented explicitly in the experimental data base, as opposed to retrieved while processing a probe, these factors should have no effect.

Research by Naus (1974; Naus, Glucksberg, & Ornstein, 1972) suggests that a directed-entry search model (using semantic category information to direct the search) may not apply in a RT item-recognition memory task when memory sets are small, vary from trial to trial, and involve only a few categories. Probe items in Naus' task were single words; on negative trials they were unrepresented exemplars from one of the categories represented by the memory set items. She found (Naus, 1974, Exp. 1; Naus et al., 1972) that RT depended on the total memory set size, but that the increase in RT for each additional item in irrelevant category subsets was half that for items in the relevant subset; that is, the slope of the RT vs. total set-size function was less for multi-category than for single category memory sets. Quantitative analyses of the results led her to conclude that selection of a subset to search was random (i.e., non-directed), but once examination of a subset was initiated it continued even when it was the irrelevant category subset. However, if the relevant category subset was examined first, then a response was made without examining the irrelevant subset (see Figure 8). Thus, on half the trials, words from the irrelevant category were searched. Naus called these operations a random-entry search process. Other investigators (Atkinson et al., 1974; Burrows & Okada, 1974, Exps 1, 2; Crain & DeRosa, 1974; Kaminsky and DeRosa, 1972) also have reported effects of irrelevant subset size using small organized memory sets in an RT recognition task. However, the data for external and internal negative probes in some of these experiments create a difficulty for the random-entry model. As in the cases cited above, external negative probes were responded to more

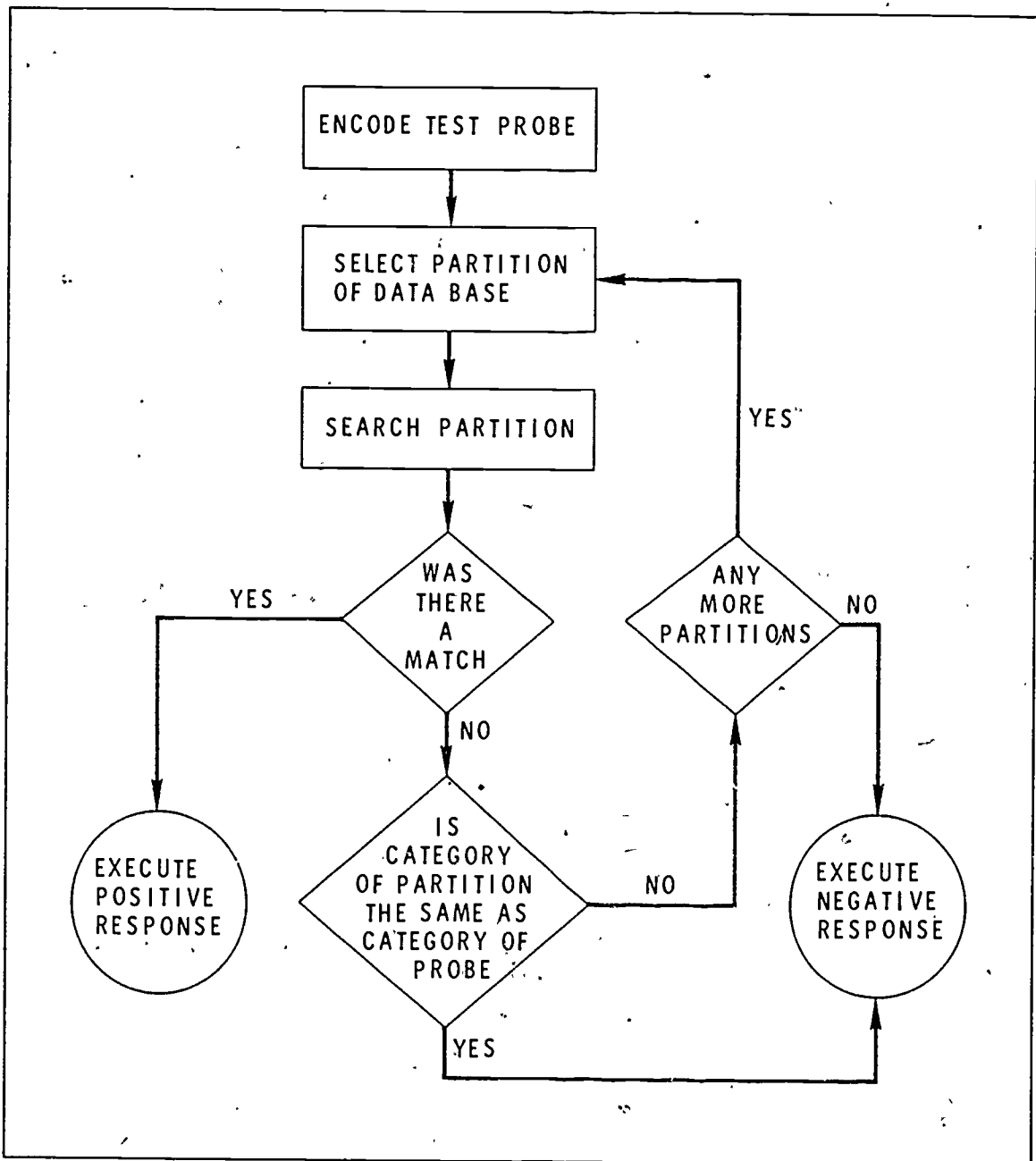

Figure 8. A random-entry search process for an organized data base. Any partition of the data base may be searched, but search terminates after the partition representing the memory set items in the same category as the test item has been searched.

quickly than internal negative probes, with minimal effect of set-size variables (Atkinson et al., 1974). The implication is that external negative probes are rejected without examining any memory set items; thus, category membership is determined prior to the non-directed search, contrary to the assumption of the random-entry model.

Further evidence against the generality of a directed-entry model that uses category information to direct the search within a data base comes from translation tasks (Cruse & Clifton, 1973; Juola & Atkinson, 1971). In the Juola and Atkinson experiment, one group of subjects was presented with memory sets containing from one to four names of taxonomic categories and was tested with single words; the subjects were to decide whether or not the probe word was an exemplar from one of the categories in the memory set. According to the logic of the two stage model, an efficient strategy is first to retrieve the name of the category associated with the probe word and then to compare that category name with those in the memory set. The name retrieval operation adds a constant to the processing time regardless of memory set size, but the search process is the same as that in a typical RT item-recognition memory task. Thus, the intercept of the RT vs. set-size function should be greater in the Juola and Atkinson (1971) task than in the prototype RT recognition task, but the slopes of the two functions should be the same. Contrary to this prediction, the slope was about four times greater in the translation task than in a control condition using an item recognition task. Similar slope increases have been found using other types of translation functions (Cruse and Clifton, 1973). One interpretation is that, in translation

tasks, category information is retrieved only as each memory set item is examined during the course of a non-directed search (as in the random-entry model)

While probes do not seem to be translated prior to search, an experiment by Smith and Abel (1973) suggests that entire memory sets may be transformed prior to presentation of a probe when the set of potential probes is sufficiently well-defined. Inverting the Juola and Atkinson task (1971), Smith and Abel presented memory sets containing from five to seven words that were drawn from two or three different taxonomic categories. Probes were category names and the decision was whether any words in the memory set belonged to the probe category. Mean RT increased with the number of different categories represented by the memory set words, but did not depend on the size of the probed subset or the size of the total memory set. The explanation offered by Smith and Abel was that the exemplars in memory sets are translated into the minimal number of category names prior to the onset of the probe. This strategy was viable in their task, but not in the Juola and Atkinson task where it is impractical to generate and store all the exemplars belonging to a category.

A rationale for divergent results

The findings cited above indicate that the search of an organized data base may involve either directed- or random-entry processes, but they do not specify the conditions under which a particular process will be used. However, there are some procedural variables that may contribute to outcomes that are in accord with a

directed-entry model: 1) using fixed, well learned memory sets for a number of test trials (Homa, 1973; Okada & Burrows, 1973; Williams, 1971); 2) physically grouping items in the same category when they are presented for learning (Kaminsky & DeRosa, 1972); and 3) pre-cuing the organization of the memory set by giving some indication prior to the test probe of which category will be tested (Crain & DeRosa, 1974; Darley, 1974; Kaminsky and DeRosa, 1972; Okada & Burrows, 1973). Cuing seems to be the most potent of these factors, and later we will consider how it might effect various stages of processing. For the moment, we will view the three factors together as a means of increasing the availability of the organizational information used in the first stage of a directed-entry search model; we can then suggest why the directed-entry model applies to some situations and the random-entry model to others. Our explanation parallels that given by Sternberg (1969b) to justify exhaustive search in the sense that it depends on a trade-off between the times required to complete two processes. If less time is required to compare a probe with all items in a memory set than to use category information for locating the relevant partition, then the former process is selected; otherwise the latter process is selected. We can view degree of learning, grouping of memory set items, and pre-cuing as factors that facilitate the use of category information, thus making the directed-entry process more efficient and consequently more likely to be selected. Naus' (1974) results suggest, however, that category information may influence the extent of non-directed search processes, but only after the relevant subset has been entered. This result can be accommodated by proposing that the

utilization of category information and the comparison process proceed simultaneously rather than sequentially. Thus, the information needed to effectively direct search to the relevant partition may become available only after the irrelevant partition is already entered (Atkinson et al., 1974).

There is some evidence that the utilization of directed-entry and random-entry processes constitutes a rather high level strategy. Naus (1974, Exp. 2) taught subjects to use a directed-entry process even when it seemed less efficient; however, the subjects tended to return to a random-entry process in the absence of continued instruction. In addition, investigators have reported between-subject differences, indicating that individual subjects utilize different processes under the same experimental conditions (Kaminsky & DeRosa, 1972; Naus, 1974).

Search models involving mixtures of processes

When information retrieved during a non-directed search determines subsequent search processes (as in the random-entry model), mean performance over a series of test probes can represent a probabilistic mixture of different underlying processes.¹⁴ In the random-entry process, irrelevant partitions of a data base are examined on only a proportion of test trials. In a self-terminating serial search, a random number (up to the memory set size) of relevant memory structures are examined for any positive test probe; for example, if

¹⁴The term "mixture" is used in this chapter in an informal sense, rather than in the restricted sense defined in probability theory.

there are three items in a memory set, then on one-third of the test trials there is one comparison, on one-third there are two comparisons, and on the other third there are three. One consequence of mixtures is an increase in the variance of RT data. Variance data can be used therefore to differentiate models (see, e.g., Sternberg, 1974; Townsend, 1974). However, for many purposes increases in variance simply make data appear less reliable, and may contraindicate the application of hypothesis testing methods that depend on homogeneity-of-variance assumptions. Underlying process mixtures may thus serve to complicate the analysis of data and the evaluation of models

Mixtures of underlying processes might also occur if there were more than one functionally equivalent memory structure within a data base (i.e., if several memory structures match a given probe structure). Consider the data base in Figure 9 which is an elaboration of the one shown in Figure 6. When this data base is entered at the LIST node, assume that one of the two links is randomly selected. In one case (solid line), category information is encountered and directs search to the relevant subset; in the other case (broken line), a non-directed search is carried out over the entire memory set, ignoring category information. Mean performance for a series of test probes reflects a mixture of these processes: each item in the irrelevant subset increases RT half as much as each item in the relevant subset because the irrelevant items are examined only when the initial non-directed search selects the broken-line links. This mixture model is an alternative to the random-entry model proposed by Naus (1974) for her results. The additional structure (broken-line links) in the data base shifts the

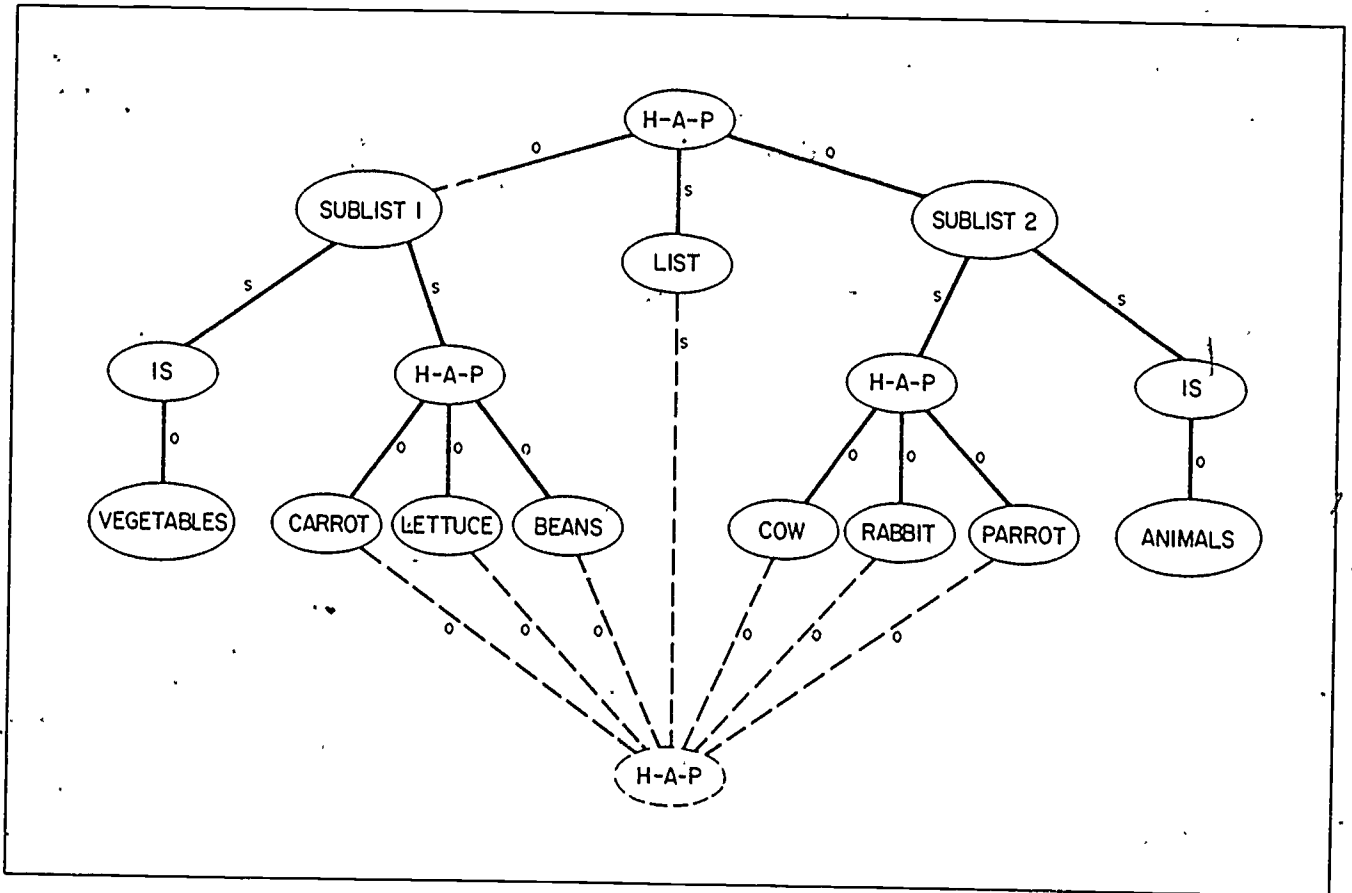

Figure 9. Elaboration of the data base shown in Figure 6. Dashed lines represent additional encodings of list-membership information; they do not include organizational information, but are sufficient for an item-recognition response.

hypothetical locus of directed and non-directed search effects, but the model still predicts the same pattern of results. (See Atkinson et al., 1974, for an elaboration of this type of model.)

Mean performance might also reflect a mixture of different underlying processes if several separate search processes can operate on a data base simultaneously. In this case, the processes may "race" against each other, with the first one to complete determining the response. Assuming that the finishing times for processes are stochastically distributed, mixtures result when processing-time distributions overlap. An interesting property of "horse-race" models is that if an experimental factor influences only one process, the change in mixture (due to a shift in the distribution for that process) can be unlike the changes that are obtained from a process mixture that is probabilistic and distributes total probability equally among the alternative processes (as in the random-entry model). In particular, in horse-race models the proportions of responses determined by different processes need not be equal. In an extreme case, if the distribution of times for one process does not overlap with that for another and has the smaller range of values, then that process will always determine the response. Thus, factors that appear to determine the processing strategy selected for a task instead could be influencing the durations of parallel memory processes (which occur under all conditions), thereby altering the basis for response without qualitatively changing processing.

A simultaneous search model that has had considerable success in accounting for data from RT sentence-recognition memory tasks is that of

Anderson and Bower (1973, 1974; Anderson, 1974). Their rather complex experiments have the virtue of permitting quite specific questions to be posed about underlying fact retrieval processes. In a prototype task, subjects learn a set of sentences, each having an identical syntactic structure, such as "In the LOCATION, the AGENT VERBed" (e.g., "In the park, the hippie laughed"); the number of different sentences in which particular concepts (i.e., LOCATIONS, AGENTS, and VERBS) appear is varied systematically. Positive test probes are single sentences from the memorized set of sentences; negative probes are sentences composed of words occurring in the memory set sentences that have been recombined in new grammatical sequences. The assumption is that in the underlying data base the number of associations leading away from a concept node increases with the number of different sentences in which it occurs (see Figure 10). Therefore, the non-directed search involved for probes containing that concept should require an increasing amount of time as it is repeated in a greater number of memory set sentences. Data from experiments of this type show that recognition RT increases with the number of sentences in the memory set in which the words in probe sentences occur. Anderson and Bower (1973) presented a model postulating simultaneous searches that are initiated from each concept in the data base (direct access to each concept) that occurs in the probe structure. For example, given the probe sentence, "In the park, the hippie laughed", the model proposes that there is direct access to the nodes for "park", "hippie", and "laughed". Associations from each of these nodes are then activated simultaneously, each process attempting to find a path to both of the other nodes. For a positive

MEMORY SET SENTENCES

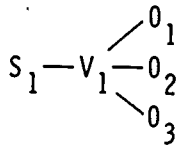

The queen rescued the professor.
 The queen rescued the grocer.
 The queen rescued the hunter.

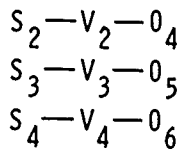

The thief tackled the singer.
 The miner helped the judge.
 The addict scolded the infant.

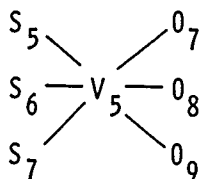

The gentleman watched the poet.
 The priest watched the officer.
 The father watched the miser.

NEGATIVE PROBES

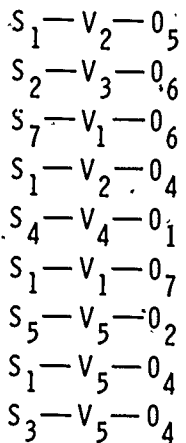

The queen tackled the judge.
 The thief helped the infant.
 The father rescued the infant.
 The queen tackled the singer.
 The addict scolded the professor.
 The queen rescued the poet.
 The gentleman watched the grocer.
 The queen watched the officer.
 The miner watched the singer.

Figure 10. "Design of RT sentence-recognition memory experiment where some concepts occur in several sentences in the memory set. For example, "queen" (S_1) and "rescued" (V_1) appear together in three sentences in the memory set. The diagrams linking subjects, verbs, and objects indicate the assumed associative complexity of the sentences in the data base. (Modified after Anderson and Bower, 1973.)

probe sentence, the first process to activate a path that matches the nodes and associations in the probe structure determines the response. Similarly, for a negative probe sentence, the first process to finish activating all possible paths without finding a match determines the response. RT depends primarily on the process beginning at the node corresponding to the concept that appeared in the fewest sentences, because that node has the fewest associations to activate.

Anderson and Bower (1973, ch. 12) contended that their simultaneous search model also applies to RT item-recognition memory tasks and explains why the slope of the RT vs. set-size function decreases when larger memory sets are used (e.g., compare the slopes obtained by Sternberg, 1966, using small memory sets with those obtained by Atkinson & Juola, 1973, using large sets). Anderson and Bower propose that there is an unambiguous path from each item in a memory set to the LIST node (as in Figure 2); note that our notation differs from that of Anderson and Bower but is equivalent for this example). When a probe item is presented the data base is entered both at the LIST node and the node representing the test item. The non-directed search from the LIST node depends on memory set size because it determines the number of paths from the LIST node to the different memory set items; on the other hand, the non-directed search from any item node involves a single path. As memory set size increases, the search initiated at the LIST node finishes before the search initiated at the item node less often, so that more responses are determined by the process not affected by set size. Therefore, as set size increases, the slope of the RT vs. set-size function decreases.

One issue that raises difficulty for the Anderson, and Bower (1973) model concerns the nature of the search processes involved in responding to negative probes consisting of items that have not been previously presented and therefore cannot be part of the data base. For these negative probes, no search process can be initiated at an item node in the relevant data base. Simply reducing the model in this case to a single search process initiated at the LIST node does not generate correct predictions for the different results obtained when negative probes contain novel items and when they contain only items that were studied. A second problem for the Anderson and Bower model are the serial position effects sometimes found in RT item-recognition tasks. Since their model incorporates no mechanism for ordering the links connected to a node, it cannot predict serial position effects without further elaborations.

Temporal Factors in Retrieval Control

In this section, we consider the effects of temporal variables in RT recognition memory tasks and their implications for fact retrieval models. By temporal variables we refer to factors such as: 1) the temporal grouping of items during presentation of the memory set, 2) the intervals between presentation of memory set items and test probes, and 3) the relative recency of different test items. Two questions are of particular interest: to what extent does temporal information provide an alternative basis for responding and to what extent is it used to direct the search process. As noted previously, organizational factors are often confounded with temporal variables. It is possible, therefore, that apparently contradictory findings about the effects of organizational variables in RT recognition memory tasks reflect differences in temporal variables associated with different experimental procedures.

Familiarity and item recognition

By definition, in a non-directed search process the search time for a negative probe is at least as great as that for a positive probe, because a negative probe requires exhaustive examination of a data base. Thus, processing must involve more than a non-directed search whenever the slope of the RT vs set size function is smaller for negative probes than for positive. Within the fact retrieval framework, obtaining a smaller slope for negative probes than for positives can be interpreted as evidence that the search for negative probes is directed to a smaller

partition of the data base; consequently, fewer comparisons are required to determine a response.

Atkinson and Juola (1974) reported several RT recognition memory studies where the slope for negative probes was less than that for positives. However, the tasks they described incorporate no obvious basis for organizing the memory set items into subsets that could facilitate directed search processes. They employed memory sets of from 16 to 32 words learned by different groups of subjects to a criterion well beyond perfect recall. Probes were single words, the implicit question being "Did LIST H-A-P word?". The results for the first presentation of test words indicate that negative probes 1) were responded to more rapidly and 2) had a smaller slope for the RT vs. set-size function than positive probes. When negative and positive probe words were repeated during the course of testing, however, the slope of the function increased for negatives, becoming greater than that for positives, which concurrently decreased; the positives also became faster overall (see Figure 11). These results suggest that different processing occurred for the different types of probes and that search processes were affected by some variable associated with repeating test probes. The fact that negative probes became slower with repetition is evidence against explanations proposing that repetition affects encoding or response learning for negative test words, since repetition would be expected to facilitate those processes (cf. Homa & Fish, 1975). Therefore, information about a probe which varies with repetition may be influencing retrieval.

Other findings question the generality of non-directed search

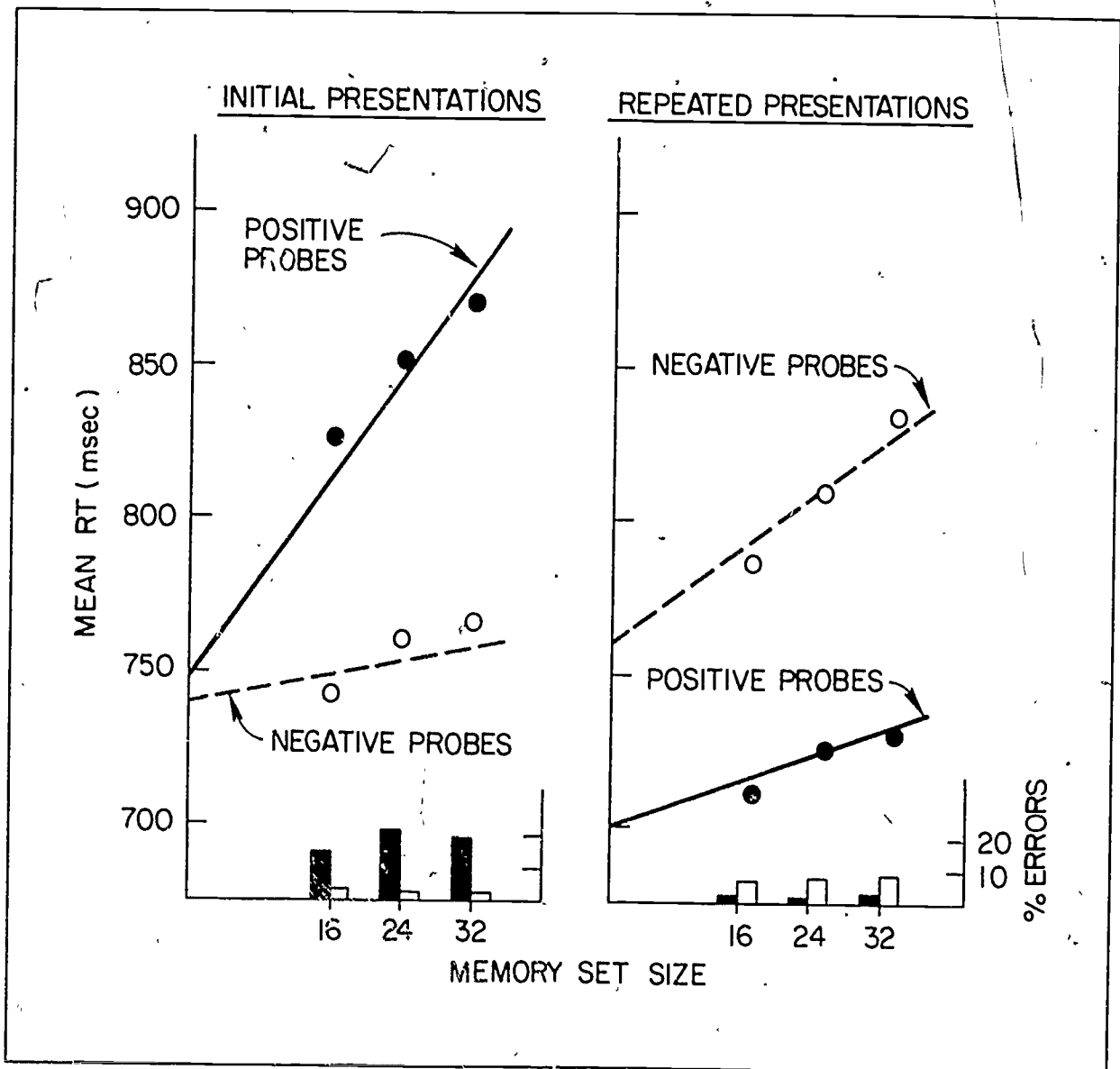

Figure 11. Mean RT and error percentages as functions of memory set size in an experiment reported by Atkinson and Juola (1974). The left panel presents data for initial presentations of positive and negative test probes, and the right panel presents the data for repeated presentations of the same items. Incorrect responses to positive probes are indicated by the shaded bars, and errors to negative probes by the open bars. The straight lines fitted to the data represent theoretical predictions of the Atkinson and Juola model.

models as sufficient explanations of RT item-recognition memory:

- 1) slope ratios vary depending on whether memory set items and probes are sampled over test trials with replacement from a small, fixed ensemble (as done by Sternberg, 1969b) or sampled without replacement from a large, functionally infinite, population of items (Banks & Atkinson, 1974);
- 2) RT for test items varies with their probability of occurrence, decreasing for higher frequency items (Theios, 1973);
- 3) RT decreases for test items that occur more than once in the memory set (Baddeley & Ecob, 1970);
- 4) as noted earlier, serial position functions that are non-linear and show a recency effect on RT are sometimes obtained.

A common aspect of these manipulations that affect RT in item-recognition memory tasks is their relation to the recency and frequency of different types of probes. This suggests that information in memory about recency and frequency may affect the fact retrieval processes involved in RT recognition memory tasks. An inspection of the task indicates that (at the time the probe is presented) potential positive test items tend to have been processed more recently and more frequently than potential negative test items-- either because items in the memory set are presented and/or rehearsed just prior to the probe or because items used as negative probes have not been presented previously in the experiment. Thus recency and frequency information could provide a basis for inferring whether or not a probe is in the memory set without comparing the probe to items in the memory set (Zechmeister, 1971).

A theory encompassing recency and frequency variables was

developed initially to explain performance in "accuracy" recognition memory tasks: in these tasks, memory sets are large and not well learned and accuracy of recognition on a delayed test is the principal dependent measure. A class of models for this type of task proposes that there is a pre-existing memory structure for each item (words, digits, letter names, etc.) in a person's lexicon. Each time an item is processed (either by being perceived or retrieved in the context of a cognitive function) its structure in the lexicon is activated (see Morton, 1970). This activation then begins to decay. The baseline level of activation and the rates of increase and decay for any structure are a function of the past frequency and recency of its activation: the exact functions in any model usually are determined empirically. The activation level of a memory structure is assumed to be a unidimensional variable, usually referred to as its strength or familiarity. In familiarity models of accuracy recognition memory tasks, the encoding of the probe item is followed by direct access to its memory structure. The familiarity value of the memory structure provides a basis for response: if the value is greater than a context-determined (e.g., by instructions or payoffs) decision criterion, a positive response is made: otherwise a negative response is made (see Banks, 1970). The viability of the decision rule derives from the fact that a high value signifies recent presentation, thus allowing the inference that the item was presented in the memory set. Errors occur when the distribution of familiarity values for positive and negative probe items overlap so that some negative

items have values greater than the criterion and vice-versa.¹⁵

Familiarity theories of recognition accuracy require elaboration to account for data from RT recognition memory tasks like Sternberg's (1966). To explain RT differences they must introduce the complicating assumption that the time to determine whether a familiarity value is above or below the criterion is a function of the 'distance' of the value from the criterion (see, e.g., Murdock & Dufty, 1972; Thomas, 1971; Wickelgren & Norman, 1969). Thus, attempts to apply pure familiarity models to data from RT recognition memory tasks seemed cumbersome in comparison to search models for the same data.¹⁶ The results reported by Atkinson and Juola (1974) and others (e.g., Zechmeister, 1971) suggest, however, that familiarity mechanisms might be useful in explaining some of the findings from RT item-recognition memory tasks.

Atkinson and Juola (1974) proposed a model for RT recognition memory tasks in which performance reflects a probabilistic mixture of decisions based on familiarity evaluations and on non-directed search

¹⁵Note that this process is proposed for recognition only; recall is assumed to involve a search through a data base representing the presentation of the memory set as an event. To make use of some current terminology, familiarity is retrieved from type (primary) nodes representing items, whereas events are represented by associating token (secondary) nodes. Each time a new memory involving an item is stored, a new token node is formed for that item.

¹⁶We see here the type of theoretical lability noted earlier. Pure search models produce set-size effects on RT by increasing the number of comparisons while holding comparison time constant. Pure familiarity models produce the same effects by varying comparison time while limiting the number of comparisons to one by means of direct access retrieval.

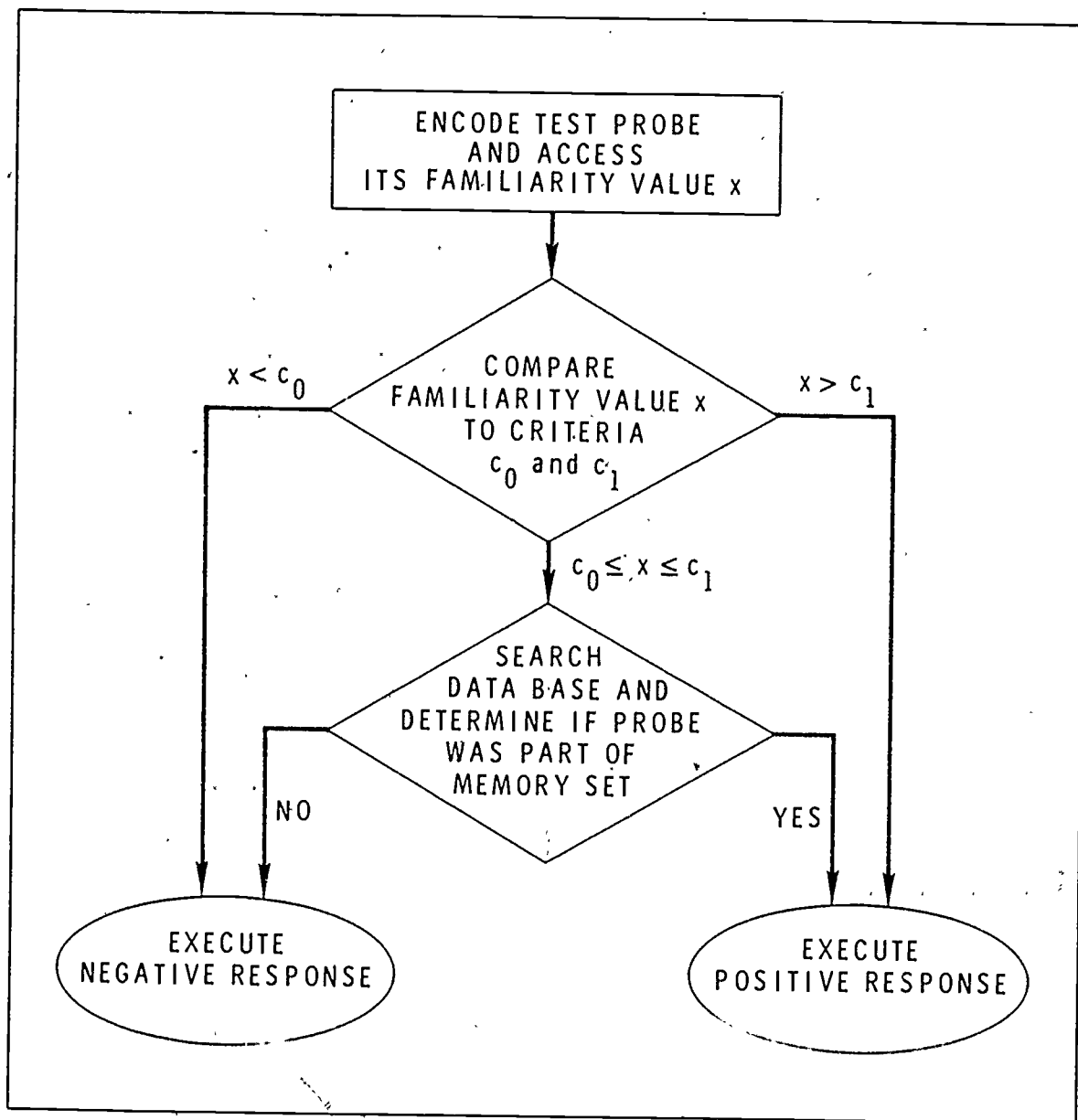

Figure 12. Flow chart for the Atkinson and Juola (1974) model. Responses are based on a probabilistic mixture of processes involving the evaluation of item familiarity and non-directed memory search.

processes (see Figure 12). When a probe item is presented, its familiarity value is obtained by direct-access retrieval and first evaluated against two decision criteria (see Figure 13). If the familiarity value is above the upper criterion, then the test probe is assumed to be a member of the memory set and a positive response is initiated without further processing; similarly, if the value is below the lower criterion, a negative response is initiated. If, however, the familiarity value lies between the two criteria (where there is the greatest overlap between the familiarity distributions), then a search is initiated in the data base representing the memory set. The time to perform the familiarity evaluation is assumed to be constant for all probes regardless of memory set size, whereas the time for the search process increases with memory set size. Predicted RT therefore increases with set size, with the slope of the function depending on the proportions of familiarity- versus search-based responses: as the proportion of familiarity-based responses approaches one, the slope approaches zero. Errors are generated by the familiarity evaluation process when part of the distribution for negative items exceeds the high criterion and when part of that for positive items falls below the low criterion: the non-directed search process is assumed to be error free.

The effect of repeating positive and negative test probes in the Atkinson and Juola model is to increase the means of both familiarity distributions relative to the decision criteria, thus altering the mixtures of familiarity-based and search-based responses. Specifically, fewer familiarity-based decisions occur for negative probes and more for

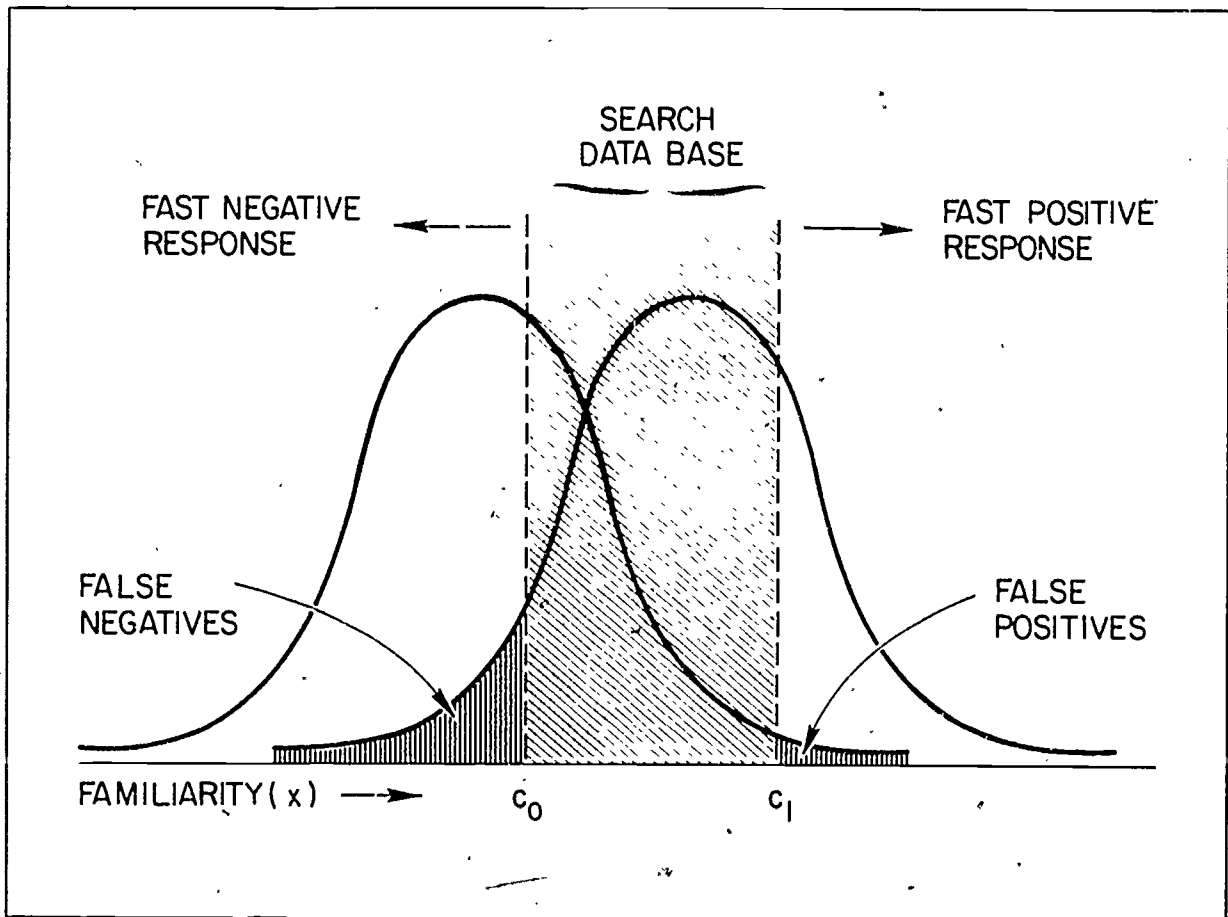

Figure 13 Relationship between processing and item familiarity in the Atkinson and Juola model. The familiarity of negative test items is represented by the leftmost distribution, and positive items by the rightmost distribution. Familiarity values to the left of the lower criterion (C_0) lead to negative responses, and those to the right of the upper criterion (C_1) lead to positive responses. Values between C_0 and C_1 do not reliably discriminate between positive and negative items, and in that case the data base is searched to determine a response.

positive probes. The model, therefore, accounts for the interaction of repetition, set size, and probe-type factors on RT data; it also accounts for the error data presented by Atkinson and Juola (1974). In general, models incorporating a mixture of search and familiarity processes are useful in explaining many RT effects that are inconsistent with pure search models-- particularly, effects where some independent variable influences the recency and frequency of different items (and therefore their familiarity) or response bias (and therefore the underlying decision criteria). For example, in studies employing categorized memory sets, the model explains why RT for negative probes drawn from unrepresented categories is both relatively fast and insensitive to changes in memory set size: If the familiarity distribution for external negative probes lies almost completely below the lower criterion, non-directed search processes will rarely occur; consequently, RT to these probes will depend minimally on factors, like memory set size, that influence the search processes (Atkinson et al., 1974).

The extent of familiarity-based responding in the RT recognition task becomes evident in variants of the task that presumably minimize or eliminate inferences about memory set membership based on recency and frequency information. Translation tasks may constitute a context where familiarity plays no role, since the items that appear as probes (both positive and negative) are not the same as those in the memory set. The relatively large slopes observed in translation tasks could represent the "true" rate of memory comparisons (because the situation eliminates familiarity as a basis for response), rather than the additional time

required to transform each item in the memory set. More direct evidence about the role of familiarity comes from experiments where the memory set is organized as several named subsets (i.e., labeled sublists) and test probes consist of a subset name and an item, the implicit question being "Did this subset H-A-P this item?". By using negative probes consisting of items that belong to a subset other than the one named in the probe, recency and frequency differences between positive and negative probes are eliminated.¹⁷ Glass, Cox, and Levine (1974) had subjects memorize two 20-word lists (LIST A and LIST B) and on alternate tests asked "Is this a LIST A (B) word?". The words used as negative probes were from LIST B if the question was about List A and vice-versa. After several tests of the words in both lists, half the subjects were shifted to a condition where negative probes were words not previously used in the experiment. Mean RT for both positive and negative probes dropped about 200 msec, relative to that for subjects who continued in the original condition. Introducing negative probes involving new words presumably allowed responses to be made on the basis of familiarity instead of non-directed search. The large RT difference indicates that memory search is infrequent when there are familiarity differences between probes

Other studies, where familiarity differences between positive and negative probes were eliminated, have found RT vs set-size functions with slopes that are substantially greater than those found in the

¹⁷ In addition, test items are associated with both types of responses, eliminating the chance of some type of simple response learning during the course of testing.

prototype RT recognition memory task. Mohs, Wescourt, and Atkinson (1975) had subjects learn six named lists that varied in size from two to six words per list. Test probes consisted of the simultaneous presentation of a list name and a word. For positive probes the word was a member of the probed list; for negative probes the word was selected from one of the other five lists. The RT vs. set-size function for positive probes had a slope of about 150 msec in contrast to slopes about 25 to 50 msec (Cavanaugh, 1972) obtained when response type is confounded with familiarity differences.¹⁸ Mean RT also increased with serial position for positive probes, indicating a self-terminating search process. For negative probes, mean RT depended on both the size of the probed list and the size of the list from which the probe word was selected. The results were interpreted in terms of a search model, similar to that of Anderson and Bower (1973), in which simultaneous non-directed searches of the data base start from representations of both the list name and the word in the test probe. Again, the magnitude of RT effects in these studies indicates that the true rate of non-directed search may become apparent only when item familiarity cannot provide an alternative basis for responding.

An experiment by Okada and Burrows (1974, Exp. 3) provides a more direct indication of processing differences for negative probes differing in recency. Prior to each probe they presented a memory set

¹⁸ However, if, in a task like that of Mohs, Wescourt, and Atkinson (1975), a probe is preceded by a cue that indicates the sublist that will be named in that probe, then slopes comparable to those found in the prototype RT recognition memory task are obtained (Appelman & Atkinson, 1975).

(two, four, or six items) divided into halves by the insertion of a pause. Before the probe appeared, one of the halves was cued as relevant; a probe was positive only if it occurred in the cued subset. Negative probes were either external (words presented for the first time in the experimental context) or internal (words sampled from the irrelevant subset on that trial). Plotting RT vs. total set size, the slope was 121 msec for internal negatives and 50 msec for external negatives; the latter value is virtually identical to that obtained in a control condition where there was no pause or cueing and, consequently, no internal negatives. The positive slope in the main condition was 80 msec (greater than that for external negatives) as compared with 55 msec in the control condition. Okada and Burrows suggest that these results could reflect a dual retrieval process. The first process involves an exhaustive search of the entire data base and is sufficient to reject external negative probes. The second process involves a slower, self-terminating search of the data base for memory structures that are "marked" in some way as relevant; that is, that they were in the cued subset. The second process differentiates positive and internal negative probes. However, as Okada and Burrows note, certain aspects of the data strain this explanation. It seems to us that their results could be explained in terms of a model incorporating a familiarity process, since the pause and cueing manipulations can be viewed as factors introducing familiarity differences between items in the relevant and irrelevant subsets. In the control condition, both positive and negative responses are based on a mixture of search and familiarity processes. In the experimental condition, the fact that

items in the non-cued set could appear as negative probes reduces or eliminates the use of high familiarity as an indicator of positive set membership; internal negative and positive probes require a search to respond. Thus, slopes for these probe types are higher than in the control condition. External negative probes in the experimental condition are comparable to negative probes in the control condition (low familiarity is still a reliable indicator that the probe was not in the positive set) and the slopes for these probe types are essentially identical.

In the Atkinson and Juola model, retrieval is controlled in the sense that the decision to search the data base depends on the outcome of the familiarity evaluation. Usually, however, subjects in RT recognition memory tasks are immediately aware of their errors, even as they are making their response (Atkinson and Juola, 1974). Therefore, it seems that the search process is not really bypassed, but instead that its result becomes available only after a response based on familiarity has already been initiated. Perhaps, the search process is executed to confirm the appropriateness of the decision criteria adopted by the subject. Alternatively, the processes of evaluating familiarity and executing a search of the data base could proceed in parallel (instead of sequentially as in the Atkinson and Juola model) with the first process to finish determining the response. In a parallel process model, the familiarity of the probe item would be evaluated against a single decision criterion, the duration of this process varying inversely with the distance of a familiarity value from the criterion. Thus, as in the Atkinson and Juola model, responses will reflect a

mixture of familiarity and search processes determined by the relation of the decision criterion to the parameters of the familiarity distributions. How one could empirically differentiate these two familiarity-and-search mixture models is not obvious; both are complex enough that only minor changes in the assumptions of either model can make them consistent with a range of data. We believe that the difficulties involved in opting for one or the other of these models are representative of the problems confronting the more general enterprise of developing theories of memory retrieval. Theoretical issues are being posed at a level of abstraction that may exceed the power of resolution inherent in present experimental methodology (Norman, 1970).

One reason for proposing pure search models for RT recognition memory data was that they seem more parsimonious than the pure familiarity theories used to explain data from accuracy recognition memory tasks. However, models proposing mixtures of underlying processes to account for a diverse range of phenomena are themselves rather complicated. An issue, therefore, is whether mixture models are preferable to elaborated, pure familiarity models with comparable explanatory power. We are not suggesting that non-directed search processes do not operate in human memory, but rather that they may not play a role in some RT item-recognition tasks. The main motivation for incorporating a search process into mixture models is to provide a mechanism for set-size effects. There is little else in the data that necessitates a search process. Set-size effects on RT can be generated by pure familiarity models if we assume that the means and variances of familiarity distributions vary with memory set size. This assumption is

not unreasonable, given that set size may be confounded with degree of learning and with the duration of the interval between the study of an item and when it is tested. Thus, on the basis of parsimony, pure familiarity models (e.g., Baddeley & Ecob, 1970) may be preferable to mixture models as accounts of RT item-recognition data (Monsell, 197).

Retrieval from a temporally differentiated data base

Familiarity models explain how temporal variables could affect performance in some RT recognition memory tasks by providing a basis for bypassing (or at least ignoring) non-directed search processes in deciding whether or not a test item belongs to a memory set. A second question about temporal variables in fact retrieval is whether they serve to structure data bases, thus allowing directed search processes to operate. The studies that bear on this question manipulate the organization of memory sets by differentiating subsets of items along temporal dimensions. One of the original motivations for these studies was to examine the interdependence of retrieval operations in short- and long-term memory stores. While the distinction between short- and long-term stores presupposes a theoretical organization of the memory system that remains controversial, the experimental procedures unquestionably manipulate the recency and frequency of different memory set items.

In these experiments, the memory set consists of two subsets: 1) one subset is a fixed list memorized prior to the test session (LT set); and 2) the other subset is a small, additional list presented before each probe and relevant only for that one test (ST set).

Positive test probes consist of an item from either the LT set or the ST set; negative test probes consist of an item from neither memory subset. As in other procedures employing organized memory sets (e.g., Naus, 1974), the data of primary interest are how RT for the different types of probes varies with the sizes of the two subsets; specifically, the operation of a directed search process can be inferred when RT for positive probes from one subset is independent of the size of the other subset.

Forrin and Morin (1969) employed ST and LT sets each composed of from one to three letters. ST set items and negative probes were sampled with replacement over trials from the same ensemble of letters. In addition to the main condition described above, subjects also were tested in two control conditions: 1) LT set only and 2) ST sets only. Summarizing the results for positive probes, RT increased with relevant subset size (i.e., RT for positive ST probes increased with ST set size) but did not vary with the size of the irrelevant subset. For negative probes, RT increased with ST set size, but did not vary with LT set size. The results from the two control conditions (which involved single memory sets) showed faster RT for both positive ST and LT probes than in the main condition. Thus, while RT for positive probes was independent of the size of the irrelevant subset, it was nevertheless faster in the absence of an irrelevant subset.

One explanation for the results found by Forrin and Morin (1969) is that the familiarity of ST and LT probes directs search to the appropriate partition of a data base which has been structured by temporal variables inherent in the presentation of the two memory sets.

In this view, the differences between the two control conditions and the experimental condition reflect the additional time needed to utilize familiarity information to select a partition. One difficulty with this explanation is that RT for negative probes was independent of LT set size, indicating that these probes were compared only against the ST set. The implication, that negative probes have the same familiarity as ST set items, is somewhat anomalous.¹⁹

The explanation favored by Forrin and Morin (1969) was that partitions of the data base corresponding to the ST and LT sets were searched simultaneously for a match to the probe structure (see Figure 14). For positive probes, the search that results in a match determines search time; for negative probes the searches of both partitions must be exhaustive and, consequently, the slower process determines search time. Subsequent studies (also employing small LT sets) are consistent with the idea of independent, simultaneous searches of dual memory sets (Doll, 1971; Scheirer and Hanley, 1974). There is some dispute, however, as to the nature of the variable that functions to differentiate the memory sets. A study by Scheirer and Hanley (1974) reported results from two experimental conditions: 1) a condition in which both ST and LT sets were digits or both were letter bigrams; and

¹⁹There are additional complications: 1) The results for LT probes should be evaluated in light of findings of unstable set size effects when individual test items are always associated with the same response (Kristofferson, 1972; Simpson, 1972): 2) since ST sets and negative probes were sampled with replacement from the same letter ensemble which was disjoint from the LT set, perceptual distinctions between the sets might have existed, providing another basis for directing search to the appropriate data base.

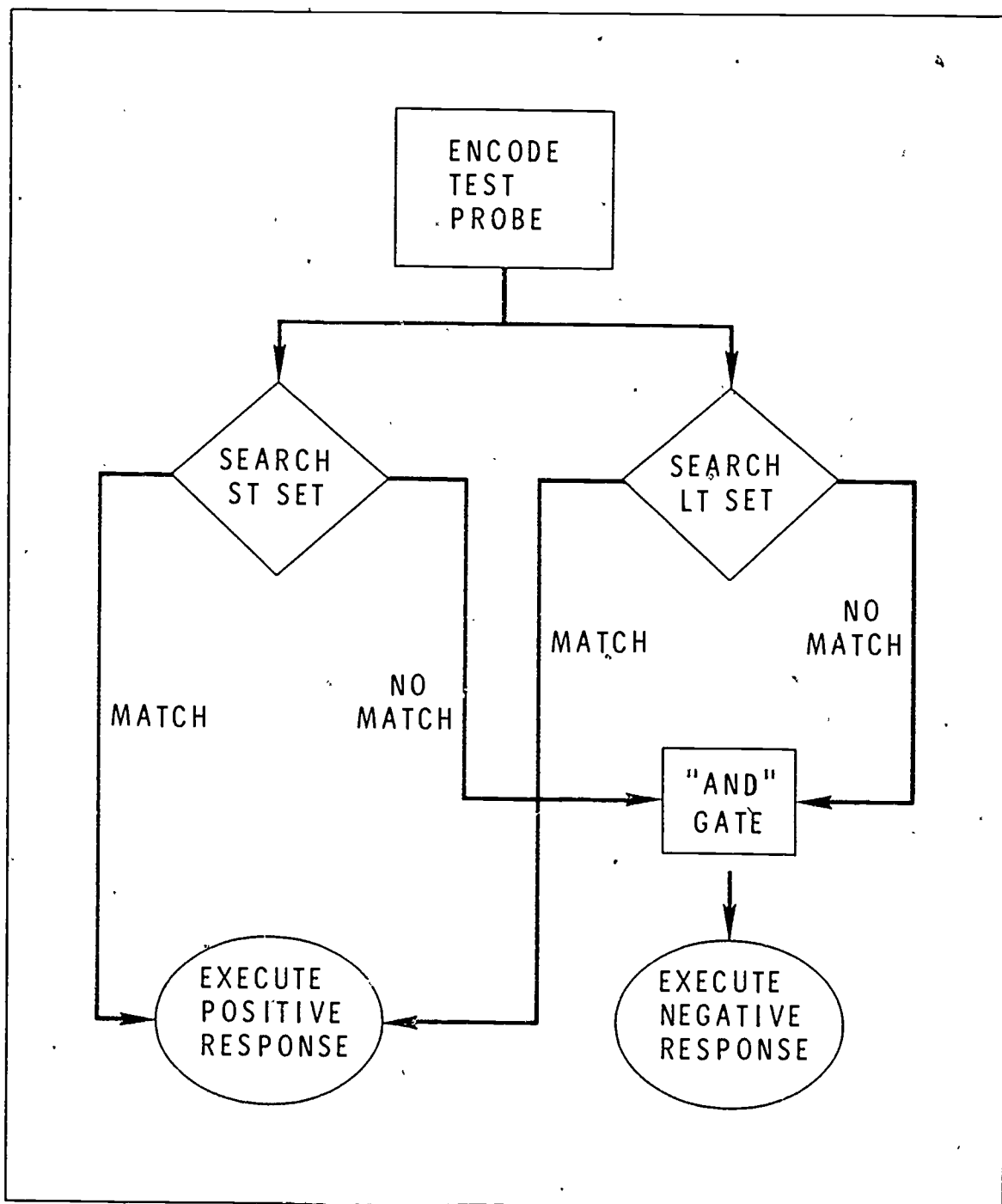

Figure 14. Flow chart for a model in which partitions of a temporally organized data base are searched simultaneously. Ascertaining a match in either search leads to immediate execution of a positive response; negative responses must wait until both searches finish without finding a match.

2) a condition in which one subset was digits and the other consisted of bigrams. In contrast to the results of Forrin and Morin (1969), Scheirer and Hanley found that RT was independent of irrelevant set size only when the two subsets were conceptually (or perhaps perceptually) discriminable: temporal differentiation alone resulted in effects of the irrelevant subset size somewhat smaller than those of the relevant subset size, suggesting a random-entry search process like that described by Naus (1974). Since, Forrin and Morin may have confounded perceptual and temporal differences between ST and LT sets, the role of temporal variables in their dual set procedure is unclear.

Other studies of the effects of temporal variables have employed the Forrin and Morin (1969) paradigm, but with much larger and extremely well memorized LT sets. The use of large LT sets should enhance the temporal discriminability of LT and ST sets by decreasing the chance that items in the LT set are rehearsed along with those in the ST sets. Wescourt and Atkinson (1973) had subjects memorize a 30-word LT set prior to the test session; before each test trial a new ST set, containing from zero to four additional words, was presented. Probes were single words that required a positive response if they belonged to either the LT or the ST set, and a negative response otherwise. In a within-subjects control condition, subjects were told to disregard the LT set, and LT set words never appeared as test probes. Thus the control condition involved the presentation of a new ST set on each trial (varying from one to four words), with the subject responding on the basis of whether or not the probe was a member of the ST set--essentially a replication of the RT item-recognition memory task

described by Sternberg (1969b). The results for the dual-set condition were: 1) RT for test items drawn from the ST set increased with the size of the ST set; and 2) RT for test items drawn from the LT set and for negative test items was constant as the size of the ST set varied from 1 to 4 items but in both cases was faster when there was no ST set (see Figure 15). The results were interpreted in terms of a model, like that of Forrin and Morin (1969), in which the ST and LT sets are processed simultaneously (see Figure 14). The data from the control condition seems to rule out an alternative explanation that the familiarity of the probe was utilized to direct search to the appropriate data base. If this were the case, then the intercept of the RT vs. ST set-size function for ST probes in the dual-set condition should have been greater than the intercept of the corresponding function in the control condition, reflecting the additional processing involved in locating the relevant subset. The slopes of the two functions should have been equal, since the non-directed search of the ST sets would be the same in both conditions. While the data uphold the expectation about the functions' intercepts, the slope in the control condition was about 40% greater than that in the main condition, suggesting that the search of the ST sets differs in the two conditions.

The slope difference between the control condition and dual-set condition in the Wescourt and Atkinson (1973) study raises a problem for the simultaneous search model. If the search processes are of limited capacity (most viable parallel processing models are), then the search rate should be slower in the dual-set condition where capacity is shared with the processing of the LT set. However, the slope difference was in

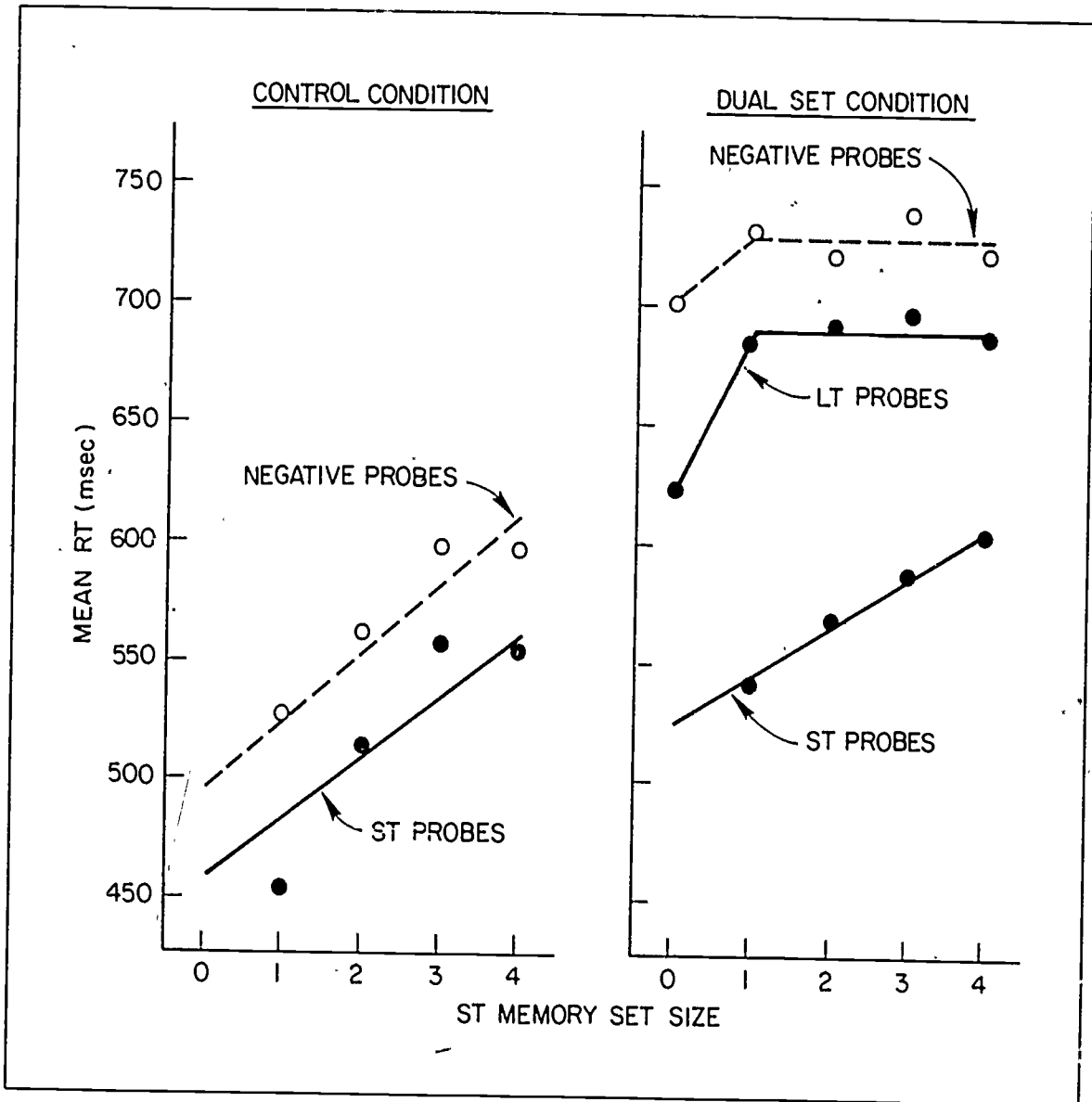

Figure 15. Mean RT and error percentages as a function of ST set size in an experiment where the total memory set was temporally organized. The left panel represents blocks of test trials where only the ST set was tested, and the right panel blocks in which both ST and LT sets were tested. The straight lines fitted to the data are theoretical predictions from a model incorporating the assumption that ST and LT sets are searched simultaneously in the dual set condition.

the opposite direction. This result can be accommodated in the simultaneous search model by inserting a stage involving familiarity evaluation and assuming that the familiarity distributions differ for the corresponding types of probes in the dual-set condition and the control condition. Thus the slope difference can be explained in terms of differing mixtures of familiarity- and search-based responses (Atkinson & Juola, 1974; Atkinson et al., 1974).

The Wescourt and Atkinson (1973) experiment and subsequent studies (Mohs and Atkinson, 1974; Mohs, Wescourt, and Atkinson, 1973) clearly demonstrate that temporal variables affect performance in RT recognition memory tasks. However, these experiments are not definitive in specifying the locus of the effect. The temporal variables could affect the hypothesized search processes, or introduce familiarity as a basis for responding, or both. This state of affairs is another instance where an inability to specify the representation of information in memory limits the inferences that can be drawn about the effects of a variable on hypothesized retrieval processes.

Informative cuing as a temporal variable in item recognition

In describing several experimental procedures, we have indicated that cuing is often used to study the effects of organization on RT recognition memory. Informative cuing has been used both to introduce organization into an otherwise homogeneous memory set (Darley, Klatzky, & Atkinson, 1972; Klatzky & Smith, 1972; Shiffrin & Schneider, 1974) and to increase the salience of organization due to other factors (Crain & DeRosa, 1974; Darley, 1974; Kaminsky & DeRosa, 1972; Naus, 1974; Okada &

Burrows, 1973). Formally, a cue may be defined as any information presented during the course of a test trial that indicates differences in the probabilities with which certain items could appear as positive or negative test probes. In practice, cues may simply be the marking or re-presentation of an item or items in the memory set; or, if the memory set is partitioned into named subsets, the cue may be the name of a subset.

The meaning of a cue depends upon instructions. For example: 1) cued items can appear as positive probes, while non-cued items never appear as test probes; 2) cued items can appear as positive probes, while non-cued items may appear as negative probes; 3) both cued and non-cued items can appear as positive probes, but with discriminably different probabilities. Obviously, cues with different meanings may entail differences in the processes initiated by a test probe. In general, cues reduce the effects of irrelevant subsets on RT for both positive and negative test probes. The most frequent interpretation of this result is that cues increase the probability that search will be directed to a relevant partition of the data base.

Most studies that are cited as evidence for the use of perceptual and semantic organization to direct search involve pre-cuing the relevant category subsets. Experiments that have studied performance in the same task with and without cuing have found that pre-cues are necessary to eliminate the effects of irrelevant subsets (Crain & DeRosa, 1974; Darley, 1974; Kaminsky & DeRosa, 1974; Naus, 1974, Exp. 2; Okada & Burrows, 1973).

We believe that cuing could effect performance in RT recognition memory tasks in several ways:

- 1) Cues allow the initial phase of search to begin before the presentation of the test probe, locating the relevant partition of the data base. Equivalently, the cued memory structures are retrieved and copied into a new data base, thereby effectively deleting the non-cued structures (DeRosa, 1969; DeRosa & Sabol, 1973).
- 2) Cues provide additional content for the probe structure that enables the search process to utilize the structure of the data base to restrict non-directed search processes. It is assumed that without the cue, the additional time required to retrieve information useful for directing the search (after presentation of the test probe) makes non-directed search of the entire data base a more efficient strategy.
- 3) Cues change the order in which the memory structures are searched by temporally differentiating subsets of items, thereby providing a basis for partitioning the data base.
- 4) Cues lead to processing (e.g., rehearsal) that changes the familiarity values of both cued and non-cued items, thereby altering the extent to which familiarity evaluations are used in responding to different types of probes.

Rather than try to untangle the many experimental findings that indicate one or another effect of cuing, it seems sufficient to remark that the mechanisms described above probably operate in varying combinations. In conjunction with other manipulations, cuing might affect processing at several loci in the memory system. In the context

of this section, it is important to note that cuing may be viewed as introducing temporal variables whose effects become confounded with organizational factors manipulated by the experimenter. Because of the many complexities involved in experiments using cues, extreme caution should be exercised in interpreting their results. Too often, results from such experiments are cited as evidence for a particular thesis when a more careful analysis indicates that any number of factors may be producing the effects.

Concluding Remarks

We began this chapter by describing an idea currently popular in cognitive psychology: there is a "pure" component of the memory system, referred to here as fact retrieval, which serves as a substrate for higher-order processes requiring information stored in memory. Relying on certain intuitive ideas, we considered how fact retrieval could be experimentally isolated from aspects of remembering that involve inference and problem solving. This discussion was intended to demonstrate why the methodology and paradigm developed by Sternberg (1966, 1969a, 1969b) have been widely used to investigate fact retrieval.

Subsequently, we described some of the theoretical constructs adopted in models of fact retrieval and illustrated the types of results cited to argue for their validity. We especially stressed the idea of directed and non-directed search processes and the experimental procedures designed to discover their respective roles in fact retrieval.

Finally, we presented a more detailed evaluation of how temporal variables (e.g., manipulations of recency and frequency information) influence fact retrieval. Rather than summarize this discussion, we want to mention briefly its relevance to the prior sections. It seems clear that temporal variables can be a major determinant of performance in tasks intended to study fact retrieval; they provide a basis for alternative inferential mechanisms to play a role in responding to certain types of probes, increasing the difficulty of using behavioral

data to infer the nature of fact retrieval processes per se. In addition, experiments designed to investigate the effects of perceptual and semantic organizations on fact retrieval often confound these factors with temporal variables, so that the models proposed for these effects may reflect incorrect assumptions about memory structure and processing.

Developments like the additive factors method described by Sternberg (1969a) have enabled information processing theorists to make more definitive statements about the relations between task variables, performance, and hypothesized memory structures and processes. The extensive research and theory of Anderson and Bower (1973) for sentence memory also have contributed toward understanding how certain data bases are structured and searched. In general, descriptions of structures and processes in fact retrieval models have become more detailed, with a corresponding increase in the complexity of research designed to resolve questions about alternative formulations.

Unfortunately, there are limitations on the complexity of behavioral experiments; for example, only a limited number of factors can be manipulated in an experiment if there is to be sufficient data for hypothesis testing and model fitting. Explanations and models for experimental results, therefore, sometimes include strong assumptions that are not necessarily dictated by those results; consequently, such assumptions are not always accepted by other theorists. In some cases, theoretical analysis seems to have transcended our ability to define experimental situations that permit us to select from among opposing theories. In particular, different fact retrieval models may involve

trade-offs between the complexity of structure and the complexity of process that they postulate; one model may explain data with simple structure and complicated processes, whereas an alternative model may involve more complicated structure, but simpler processing. It is probably fair to conclude that while there is considerable data relevant to a fact retrieval analysis of memory, there are a bewildering number of alternative models for these results with no unequivocal basis at present for selecting among them.

REFERENCES

- Anders, T. R. Retrospective reports of retrieval from STM. Journal of Experimental Psychology, 1971, 90, 251-257.
- Anderson, J. R. Retrieval of propositional information from long-term memory. Cognitive Psychology, 1974, 4, 451-474.
- Anderson, J. R., & Bower, G. H. Human associative memory. Washington, D.C.: Winston, 1973.
- Anderson, J. R., & Bower, G. H. A propositional theory of recognition memory. Memory & Cognition, 1974, 2, 406-412.
- Appelman, I. B., & Atkinson, R. C. Search of list structures stored in long-term memory. Journal of Verbal Learning and Verbal Behavior, 1975, 14, 82-88.
- Atkinson, R. C., Herrmann, D. J., & Wescourt, K. T. Search processes in recognition memory. In R. L. Solso (Ed.), Theories in cognitive psychology. Potomac, Md.: Erlbaum, 1974.
- Atkinson, R. C., Holmgren, J. E., & Juola, J. F. Processing time as influenced by the number of elements in a visual display. Perception & Psychophysics, 1969, 6, 321-326.
- Atkinson, R. C., & Juola, J. F. Factors influencing speed and accuracy of word recognition. In S. Kornblum (Ed.), Attention and performance, IV. New York: Academic Press, 1973.
- Atkinson, R. C., & Juola, J. F. Search and decision processes in recognition memory. In D. H. Krantz, R. C. Atkinson, and P. Suppes (Eds.), Contemporary developments in mathematical psychology. San Francisco: Freeman, 1974.
- Atkinson, R. C., & Wescourt, K. T. Some remarks on a theory of memory. In P. Rabbitt (Ed.), Attention and performance, V. New York: Academic Press, 1975.
- Baddeley, A. D., & Ecob, J. R. Reaction time and short-term memory: Implication of repetition effects for the high-speed exhaustive scan hypothesis. Quarterly Journal of Experimental Psychology, 1973, 25, 229-240.
- Banks, W. P. Signal detection theory and human memory. Psychological Bulletin, 1970, 74, 81-99.
- Banks, W. P., & Atkinson, R. C. Accuracy and speed strategies in scanning active memory. Memory & Cognition, 1974, 2, 629-636.

- Bobrow, D. G., & Collins, A. M. Representation and understanding. New York: Academic Press, 1975.
- Bower, G. H. A multicomponent theory of the memory trace. In K. W. Spence and J. T. Spence (Eds.), The psychology of learning and motivation, 1. New York: Academic Press, 1967.
- Burrows, D., & Okada, R. Serial position effects in high-speed memory search. Perception & Psychophysics, 1971, 10, 305-308.
- Burrows, D., & Okada, R. Scanning temporally structured lists: Evidence for dual retrieval processes. Memory & Cognition, 1974, 2, 441-446.
- Cavanagh, J. P. Relation between the immediate memory span and the memory search rate. Psychological Review, 1972, 79, 525-530.
- Chase, W. G., & Calfee, R. C. Modality and similarity effects in short-term memory. Journal of Experimental Psychology, 1969, 81, 510-514.
- Checkosky, S. F. Speeded classification of multidimensional stimuli. Journal of Experimental Psychology, 1971, 87, 383-388.
- Clifton, C., Jr., & Birenbaum, S. Effects of serial position and delay of probe in a memory scan task. Journal of Experimental Psychology, 1970, 86, 69-76.
- Collins, A. M., & Quillian, M. R. How to make a language user. In E. Tulving and W. Donaldson (Eds.), Organization of memory. New York: Academic Press, 1972.
- Crain, R. D., & DeRosa, D. V. Retrieval of information from multiple ensembles in short-term memory. Memory & Cognition, 1974, 2, 255-260.
- Cruse, D., & Clifton, C., Jr. Recoding strategies and the retrieval of information from memory. Cognitive Psychology, 1973, 4, 157-193.
- Darley, C. F. Effects of memory load and its organization on the processing of information in short-term memory. Unpublished Ph.D. thesis, Stanford University, 1974.
- Darley, C. F., Klatzky, R. L., & Atkinson, R. C. Effects of memory load on reaction time. Journal of Experimental Psychology, 1972, 96, 332-334.
- DeRosa, D. V. Transformations on sets in short-term memory. Journal of Experimental Psychology, 1969, 83, 415-426.

- DeRosa, D. V., & Sabol, M. Transformations on sets in short-term memory: Temporal and spatial factors influencing deletion. Memory & Cognition, 1973, 1, 69-72.
- Doll, T. J. Motivation, reaction time, and the contents of active verbal memory. Journal of Experimental Psychology, 1971, 87, 29-36.
- Feigenbaum, E. A. Information processing and memory. In D. A. Norman (Ed.), Models of human memory. New York: Academic Press, 1970.
- Forrin, B., & Morin, R. E. Recognition times for items in short- and long-term memory. Acta Psychologica, 1969, 30, 126-141.
- Glass, A. L., Cox, J., & LeVine, S. J. Distinguishing familiarity from list search responses in a reaction-time task. Bulletin of Psychonomic Society, 1974, 4, 105-108.
- Hall, I. F. Verbal learning and retention. Philadelphia: Lippincott, 1971.
- Homa, D. Organization and long-term memory search. Memory and Cognition, 1973, 1, 369-379.
- Homa, D., & Fish, R. Recognition reaction time in long-term memory as a function of repetition, lag, and identification of positive and negative search sets. Journal of Experimental Psychology: Human Learning & Memory, 1975, 104, 71-80.
- Jacoby, L. L. Effects of organization on recognition memory. Journal of Experimental Psychology, 1972, 92, 325-331.
- Juola, J. F., & Atkinson, R. C. Memory scanning for words vs. categories. Journal of Verbal Learning and Verbal Behavior, 1971, 10, 522-527.
- Kahneman, D. Attention and effort. Englewood Cliffs, N. J.: Prentice-Hall, 1973.
- Kaminsky, C. A., & De Rosa, D. V. Influence of retrieval cues and set organization on short-term recognition memory. Journal of Experimental Psychology, 1972, 96, 449-454.
- Kintsch, W. Models for free recall and recognition. In D. A. Norman (Ed.), Models of human memory. New York: Academic Press, 1970.
- Klatzky, R. L., Juola, J. F., & Atkinson, R. C. Test stimulus representation and experimental context effects in memory scanning. Journal of Experimental Psychology, 1971, 87, 281-288.

- Klatzky, R. L., & Smith, E. E. Stimulus expectancy and retrieval from short-term memory. Journal of Experimental Psychology, 1972, 94, 101-107.
- Kristofferson, M. W. When item recognition and visual search functions are similar. Perception & Psychophysics, 1972, 12, 379-384.
- Landauer, T. K. Memory without organization: Explorations of a model with random storage and undirected retrieval. Cognitive Psychology, 1975, in press.
- Landauer, T. K., & Ainslie, K. I. Reaction time effects of artificial category size. Paper presented at the meetings of the Psychonomic Society, November, 1973.
- Landauer, T. K., & Streeter, L. A. Structural differences between common and rare words: Failure of equivalence assumptions for theories of word recognition. Journal of Verbal Learning and Verbal Behavior, 1973, 12, 119-131.
- Lively, B. L., & Sanford, B. J. The use of category information in a memory-search task. Journal of Experimental Psychology, 1972, 93, 379-385.
- McCormack, P. D. Recognition memory: How complex a retrieval system. Canadian Journal of Psychology, 1972, 26, 19-41.
- Meyer, D. E., Schvaneveldt, R. W., & Ruddy, M. G. Loci of contextual effects on visual word-recognition. In P. Rabbitt (Ed.), Attention and performance, V. New York: Academic Press, 1975.
- Miller, J. O., & Pachella, R. G. The locus of effect of stimulus probability on memory scanning. Journal of Experimental Psychology, 1974, in press.
- Mohs, R. C., & Atkinson, R. C. Recognition time for words in short-term, long-term or both memory stores. Journal of Experimental Psychology, 1974, 102, 830-835.
- Mohs, R. C., Wescourt, K. T., & Atkinson, R. C. Effects of short-term memory contents on short- and long-term memory searches. Memory & Cognition, 1973, 1, 443-448.
- Mohs, R. C., Wescourt, K. T., & Atkinson, R. C. Search processes for associative structures in long-term memory. Journal of Experimental Psychology: General, 1975, in press.
- Monsell, S. Information processing in short-term memory tasks. Unpublished Ph.D. thesis, Oxford University, 1973.
- Morton, J. A functional model for memory. In D. A. Norman (Ed.), Models of human memory. New York: Academic Press, 1970.

- Murdock, B. B., Jr. A parallel-processing model for scanning. Perception & Psychophysics, 1971, 0, 289-291.
- Murdock, B. B., Jr. Human memory: theory and data. Potomac, Md.: Erlbaum, 1974
- Murdock, B. B., Jr., & Dally, P. O. Strength theory and recognition memory. Journal of Experimental Psychology, 1972, 94, 284-290.
- Naus, M. J. Memory search of categorized lists: A consideration of alternative self-terminating search strategies. Journal of Experimental Psychology, 1974, 102, 992-1000
- Naus, M. J., Gluckberg, S., & Ornstein, P. A. Taxonomic word categories and memory search. Cognitive Psychology, 1972, 3, 643-654.
- Nielsen, R. S. Same-different reaction times with multi-attribute stimulus differences. Perceptual and Motor Skills, 1967, 24, 543-554.
- Norman, D. A. Introduction: Models of human memory. In D. A. Norman (Ed.) Models of human memory. New York: Academic Press, 1970.
- Norman, D. A., & Rumelhart, D. E. A system for perception and memory. In D. A. Norman (Ed.), Models of human memory. New York: Academic Press, 1970.
- Norman, D. A., & Wickelmaier, W. A. Strength theory of decision rules and latency in short-term memory. Journal of Mathematical Psychology, 1969 6, 192-208
- Okada, R., & Barrows, D. Organizational factors in high-speed scanning. Journal of Experimental Psychology, 1973, 101, 77-81.
- Oldfield, B. C. Things, words, and the brain. Quarterly Journal of Experimental Psychology, 1966, 18, 340-353
- Pacheila, R. G. The interpretation of reaction time in information processing research. In B. Kantowitz (Ed.), Human information processing: tutorials in performance and cognition. Hillsdale, N. J.: Erlbaum, 1974
- Raeburn, V. P. Priorities in item recognition. Memory & Cognition, 1974, 2, 663-669.
- Rips, L. J., Shoben, E. J., & Smith, E. E. Semantic distance and the verification of semantic relations. Journal of Verbal Learning and Verbal Behavior, 1973, 12, 1-20.
- Rumelhart, D. E., Lindsey, P. H., & Norman, D. A. A process model for long-term memory. In E. Tulving and W. Donaldson (Eds.), Organization of memory. New York: Academic Press, 1972.

- Scheirer, C. J., & Hanley, M. J. Scanning for similar and different material in short- and long-term memory. Journal of Experimental Psychology, 1974, 102, 343-346.
- Seamon, J. G. Retrieval processes for organized long-term storage. Journal of Experimental Psychology, 1973, 97, 170-176.
- Shevél, S. K., & Atkinson, R. C. A theoretical comparison of list scanning models Journal of Mathematical Psychology, 1974, 11, 79-106.
- Shiffrin, R. M. Memory search In D. A. Norman (Ed.), Models of human memory. New York: Academic Press, 1970.
- Shiffrin, R. M., & Atkinson, R. C. Storage and retrieval processes in long-term memory. Psychological Review, 1969, 76, 179-193.
- Shiffrin, R. M., & Schneider, W. An expectancy model for memory search. Memory & Cognition, 1974, 2, 616-628.
- Simpson, P. J. High-speed memory scanning: Stability and generality. Journal of Experimental Psychology, 1972, 96, 239-246.
- Smith, E. E., Shoben, E. J., & Rips, L. J. Structure and process in semantic memory: A featural model for semantic decisions. Psychological Review, 1974, 81, 214-241.
- Smith, M. C., & Abel, S. M. Memory search: When does semantic analysis occur? Perception & Psychophysics, 1973, 13, 233-237.
- Sternberg, S. High-speed scanning in human memory. Science, 1966, 153, 652-654
- Sternberg, S. The discovery of processing stages: Extensions of Donders' method. In W. G. Koster (Ed.), Attention and performance, 11. Amsterdam: North-Holland, 1969a.
- Sternberg, S. Memory scanning: Mental processes revealed by reaction time experiments American Scientist, 1969b, 57, 421-457
- Sternberg, S. Memory scanning: An informal review of recent developments. In J. A. Deutsch and D. Deutsch (Eds.), Short-term memory. New York: Academic Press, 1974.
- Theios, J. Reaction time measurements in the study of memory processes: Theory and data. In G. H. Bower (Ed.), The psychology of learning and motivation, VII. New York: Academic Press, 1973.
- Thomas, E. A. C. Sufficient conditions for monotone hazard rates: An application to latency-probability curves. Journal of Mathematical Psychology, 1971, 8, 303-332

- Townsend, J. T. A note on the identifiability of parallel and serial processes. Perception & Psychophysics, 1971, 10, 161-163.
- Townsend, J. T. Issues and models concerning the processing of a finite number of inputs. In B. H. Kantowitz (Ed.), Human information processing: Tutorials in performance and cognition. Hillsdale, N.J.: Erlbaum, 1974.
- Tulving, E. Episodic and semantic memory. In F. Tulving and W. Donaldson (Eds.), Organization of memory. New York: Academic Press, 1972.
- Wescourt, K. T., & Atkinson, R. C. Scanning for information in short- and long-term memory. Journal of Experimental Psychology, 1973, 98, 95-101.
- Williams, J. D. Memory ensemble selection in human information processing. Journal of Experimental Psychology, 1971, 88, 231-238.
- Zechmeister, E. B. Short-term recognition memory for words: Why search? Journal of Experimental Psychology, 1971, 89, 265-273.

- 211 J. Einfeld, Computers in the instructional process: A course in the cryptic. *July 31, 1973.*
- 212 S. A. Weiser, *Elementary algebra on the VisiCalc 17, 1973.*
- 213 B. W. Smith, F. L. Rawson, and P. Suppes, Structural variables affecting CAI performance on arithmetic word problems of grade-retarded middle school children. *September 4, 1973.*
- 214 P. Suppes, J. D. Fletcher, and M. Zanetti, Models of individual frequency in a computer-assisted instruction for deaf students. *October 31, 1973.*
- 215 J. D. Fletcher and M. H. Beard, Computer-assisted instruction in language art for hearing-impaired students. *October 31, 1973.*
- 216 J. D. Fletcher, Train for free: alternative presentations of spelling patterns in initial reading. *September 28, 1973.*
- 217 P. Suppes, J. D. Fletcher and M. Zanetti, Performance level of American Indian students on computer-assisted instruction in elementary mathematics. *October 31, 1973.*
- 218 J. Einfeld, A network of probabilistic model for cue to answering in semantic memory. *October 31, 1973.*
- 219 P. Suppes, The concept of obligation in the context of decision theory. (In J. Leach, R. Butts, and G. Pearce (Eds.), *Science, decision and value*. Proceedings of the fifth University of Western Ontario philosophy colloquium, 1969. Dordrecht: Reidel, 1973. Pp. 1-14.)
- 220 F. L. Rawson, Set-theoretical semantics for elementary mathematical language. *November 7, 1973.*
- 221 R. Schupbach, Toward a computer-based course in the history of the Russian literary language. *December 31, 1973.*
- 222 M. Beard, P. L. Rugh, B. W. Smith, and R. C. Atkinson, Comparison of student performance and attitude under three lesson-selection strategies in computer-assisted instruction. *December 31, 1973.*
- 223 D. G. Danforth, D. R. Rogosa, and P. Suppes, Learning models for real-time speech recognition. *January 15, 1974.*
- 224 M.R. Rugh and R. C. Atkinson, A mnemonic method for the acquisition of a second-language vocabulary. *March 15, 1974.*
- 225 P. Suppes, The semantics of children's language. *American Psychologist, 1974, 29, 103-114.*
- 226 P. Suppes and E. M. Ginnon, Grammar and semantics of one six-year-old black children's noun phrases.
- 227 N. W. Smith, A question-answering system for elementary mathematics. *April 19, 1974.*
- 228 A. Barr, M. Beard, and R. C. Atkinson, A rationale and description of the BASIC instructional program. *April 22, 1974.*
- 229 P. Suppes, Coherence of meaning. *Proceedings and Addresses of the American Philosophical Association, 1973, 46, 21-38.*
- 230 P. Suppes, New foundations of objective probability: Axioms for, revision theory. (In P. Suppes, L. Henkin, G. C. Morfit, and A. Josa (Eds.), *Logic, methodology, and philosophy of science IV: Proceedings of the fourth international congress for logic, methodology and philosophy of science, Bucharest, 1971*. Amsterdam: North-Holland, 1973. Pp.515-529.)
- 231 P. Suppes, The structure of theories and the analysis of data. (In F. Suppe (Ed.), *The structure of scientific theories*. Urbana, Ill. University of Illinois Press, 1974. Pp. 267-233.)
- 232 P. Suppes, Popper's analysis of probability in quantum mechanics. In P. A. Schilpp (Ed.), *The philosophy of Karl Popper*, Vol. 2. LaSalle, Ill.: Open Court, 1974. Pp.760-774.
- 233 P. Suppes, The promise of universal higher education. In S. Hook, P. Kertis, and M. Todorovitch (Eds.), *The idea of a modern university*. Buffalo, N. Y.: Prometheus Books, 1974. Pp. 21-32.
- 234 P. Suppes, Cognition: A survey. (In J. A. Swets and L. L. Elliott (Eds.), *Psychology and the handicapped child*. Washington, D. C.: U. S. Government Printing Office, 1974.)
- 235 P. Suppes, The place of theory in educational research. *Educational Researcher, 1974, 3 (6), 3-10.*
- 236 V. R. Charrow, Deaf English--An investigation of the written English competence of deaf adolescents. *September 30, 1974.*
- 237 R. C. Atkinson and M. R. Rugh, An application of the mnemonic keyword method to the acquisition of a Russian vocabulary. *October 4, 1974.*
- 238 R. L. Smith, N. W. Smith, and F. L. Rawson, CONSTRUCT: In search of a theory of meaning. *October 25, 1974.*
- 239 A. G. Hoberg and P. Suppes, Computer-assisted instruction in elementary logic at the university level. *November 8, 1974.*
- 240 R. C. Atkinson, Adaptive instructional systems: Some attempts to optimize the learning process. *November 20, 1974.*
- 241 P. Suppes and W. Rottmayer, Automata. (In E. C. Cortese and M. P. Friedman (Eds.), *Handbook of perception*, Vol. 1: *Historical and philosophical roots of perception*. New York: Academic Press, 1971.)
- 242 P. Suppes, The central but implicit role of logical concepts in science. (In R. S. Cohen and M. W. Wartofsky (Eds.), *Boston studies in the philosophy of science*, Vol. 20, K. F. Schaffner and R. S. Cohen (Eds.), *PSA 1972, Proceedings of the 1972 biennial meeting of the Philosophy of Science Association*, Synthese Library, Vol. 64. Dordrecht: Reidel, 1974.)
- 243 P. Suppes, M. LeVailley, and R. L. Smith, Developmental model of a child's French syntax. *December 4, 1974.*
- 244 R. L. Breiger, S. A. Boorman, and P. Arabie, An algorithm for blocking relational data, with applications to social network analysis and comparison with multidimensional scaling. *December 13, 1974.*
- 245 P. Suppes, Aristotle's concept of matter and its relation to the system concept of matter. (*Synthese, 1974, 23, 27-30.*)
- 246 P. Suppes, The scientific method in the empirical sciences. (In L. Henkin et al. (Ed.), *Proceedings of the Turkish symposium: Proceedings of symposium in pure mathematics*, 25. Princeton: R. I. American Mathematical Society, 1974.)
- 247 P. Suppes, The measurement of bound. *Journal of the Royal Statistical Society, Series B, 1974, 36, 164.*
- 248 R. Smith, TENEX TAIL. *Januar, 16, 1975.*
- 249 J. O. Campbell, E. J. Lind, and R. C. Atkinson, Predicting reading achievement from reading and ability tests using computer-assisted instruction. *January 26, 1975.*
- 250 S. A. Weiser and A. B. Cannara, Children's reading: computer programming. Experiment with language, computer and reading materials. *January 27, 1975.*

(Continued from inside back cover)

- 251 P. Suppes and M. Zanotti, Stochastic incompleteness of quantum mechanics, (Synthese, 1974, 29, 311-330.)
- 252 K. T. Wescourt and R. C. Atkinson, Fact retrieval processes in human memory, April 11, 1975.